

Assignment #1

Using the software, create the following drawing using the commands you have learned through reading below or watching the support videos.

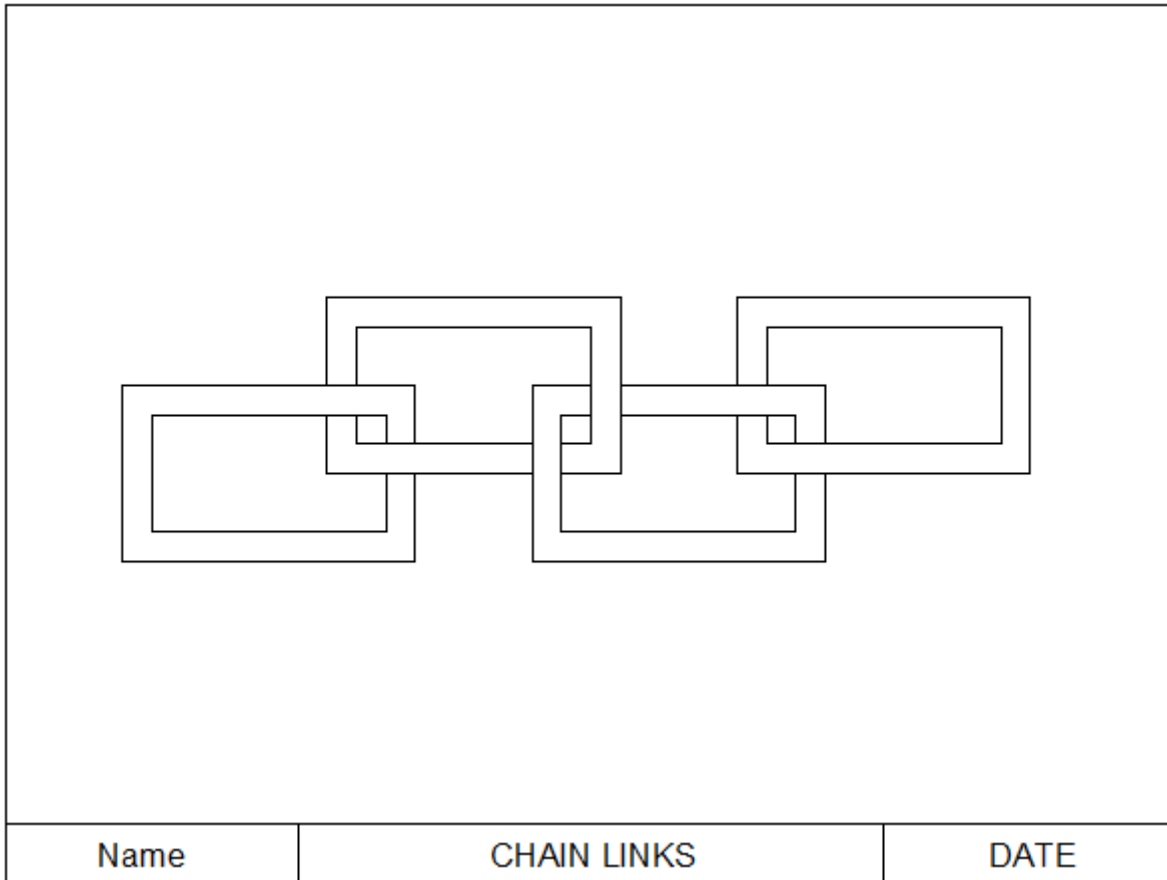

Commands/concepts to Learn in this Activity:

Absolute Coordinate Entry	Line	Move	Trim
Relative Coordinate Entry	Copy	Offset	Text
Polar Coordinate Entry	Zoom	Fillet	Print

1. Start the CAD software in a blank drawing. ([Student Video #1](#))
2. Setting Limits and Snap ([Student Video #2](#))
3. You are going to learn how to enter coordinates multiple ways by drawing lines. Understand that pressing F12 toggles what is called Dynamic Input on/off. Having Dynamic Input on/off sometimes helps or does not help when drawing lines. Make sure it is off when using command line entries. ([Student Video #3](#))

Absolute Coordinate Entry

- Command: Line (enter)
- From point: 1.5,3.5 (enter)
- To point: 4,3.5 (enter)
- To point: 4,5 (enter)
- To point: 1.5,5 (enter)
- To point: 1.5,3.5 (enter) (enter)
- A double return completes the command

The first completed square should look like this:

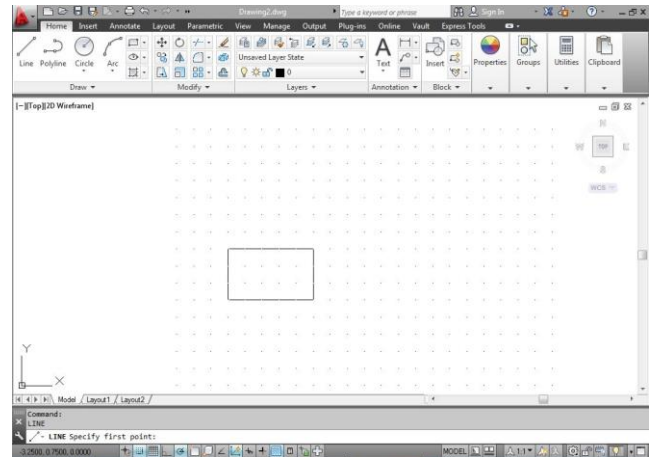

Relative Coordinate Entry

- Command: Line (enter)
- From point: 3,6(enter)
- To point: @ 2.5,0 (enter)
- To point: @ 0,1.5 (enter)
- To point: @ -2.5,0 (enter)
- "C" will Close a polygon.

You should now have two squares.
Did you save it yet?

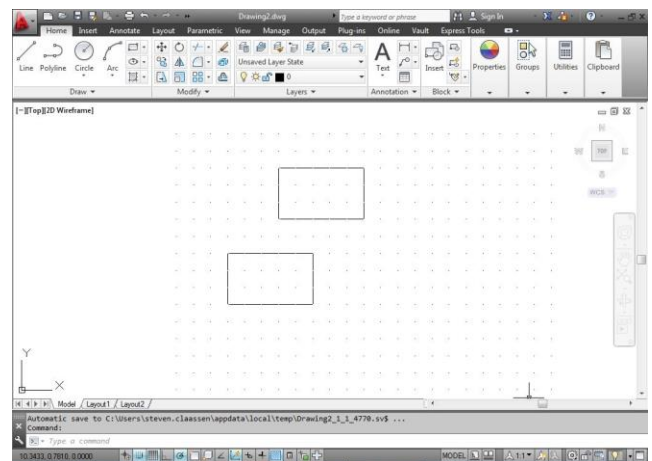

(Student Video #4)

Polar Coordinate Entry

- Command: Line (enter)
- From point: 6,2 (enter)
- To point: @ 2.5<0 (enter)
- To point: @ 1.5<90 (enter)
- To point: @ 2.5<180 (enter)
- "C" will Close a polygon.

Mouse Entry Method

- Command: Line (enter)
- From point: 7,6 (enter)

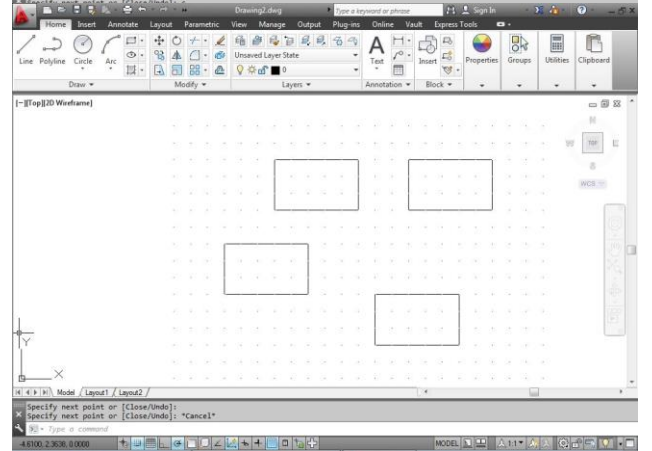
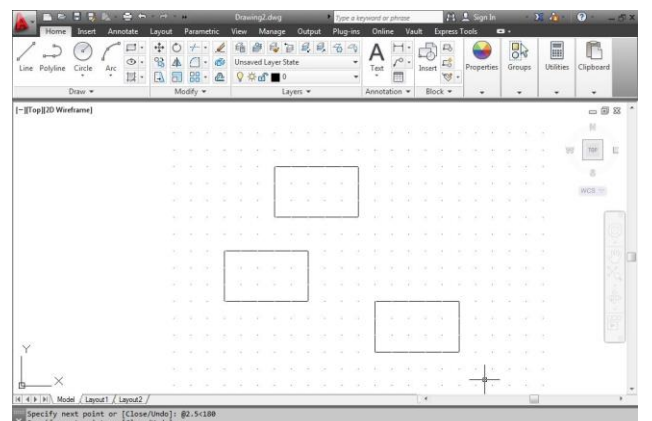

- Move mouse a length of 2.5 @ an angle of 0, left mouse click
- Move mouse a length of 1.5 @ angle of 90, left mouse click
- Move mouse a length of 2.5 @ angle of 180, left mouse click
- “ C” (enter) to close the polygon

The drawing should now have four rectangles as shown above. Keep in mind that there are different ways available for drawing lines.

4. Now we will draw 4 smaller rectangles inside the existing four rectangles using the **Line** and **Offset** commands. But first let's make the rectangles bigger on the screen. We will zoom into the rectangles.

- Command: Zoom (enter) (The capitalized letters e.g. A, D, E, W, etc are short cut keys)
- W (enter) Use the mouse to pick a point in the upper left corner, then the lower right corner. You now zoom in.

5. Now use the **Offset**, **Fillet** commands to create a box in a box. ([Student Video #5](#))

- Command: Offset (enter)
- Offset distance or through : .25 (enter)
- Select object to offset: (With the mouse pick one side of a square)
- Side to offset: (pick a point inside the square)
- Select object to offset: (repeat the above 2 steps until all the squares are doubled)
- The drawings should now look like the picture to the right. Have you saved recently?

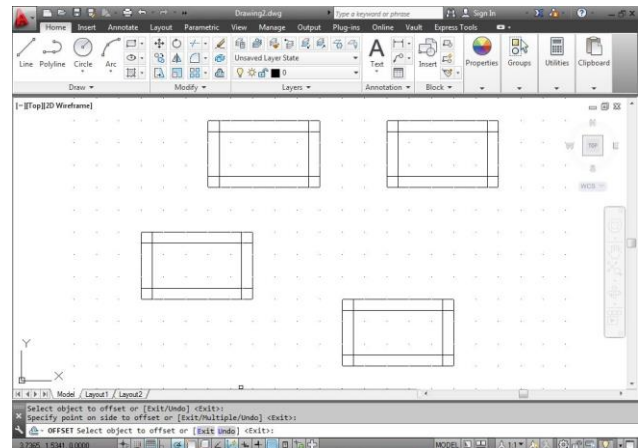

Now clean up the corners of the inside squares with the Fillet command. ([Student Video #6](#))

- Command: Fillet (enter)
- Fillet (radius=0.5000):
Radius/Settings/Polyline /: R (enter)
- Enter fillet radius <0.5000>: 0 (enter)
- Fillet (radius=0.0000):
Radius/Settings/Polyline /:

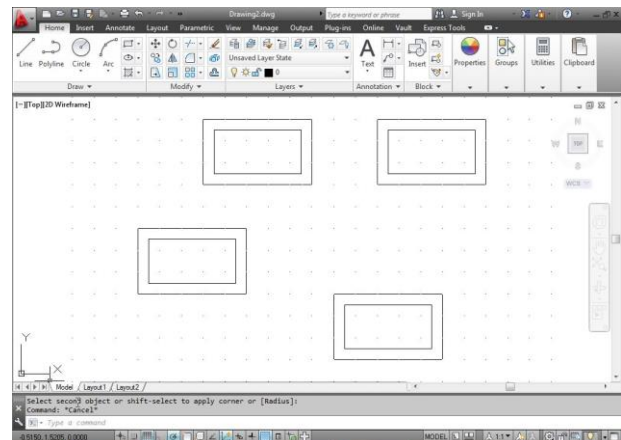

- With the mouse pick the two sides of an inner square.
- Command: Space bar or enter to repeat the fillet command
- Repeat step 4, for all four corners.

Now move the rectangles to create the chain link
([Student Video #7](#))

- Command: Move (enter)
- Highlight the second rectangle you drew by holding down the left mouse button and dragging over the entire object from right to left
- right mouse click
- Specify base point: left mouse click on the bottom left corner of rectangle
- move the rectangle to create the first chain as show to the right
- left mouse click to place it
- repeat the above process until you have all the links in place

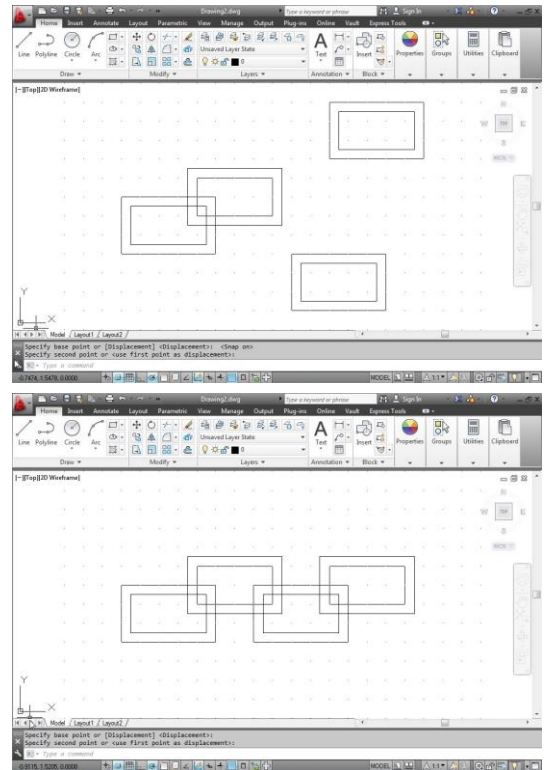

Now use the Trim command to remove the pieces out of the lines to give the appearance that the links are connected to form a chain. ([Student Video #8](#))

- Command: Trim (enter)
- Pick the 2 lines you want to trim between using the left mouse button (right mouse click)
- Pick the short pieces (left mouse button) that you want gone between the highlighted lines and they will disappear.
- Press esc to cancel
- Press space bar to repeat the command
- Your drawing should now look like this. Time to save again.

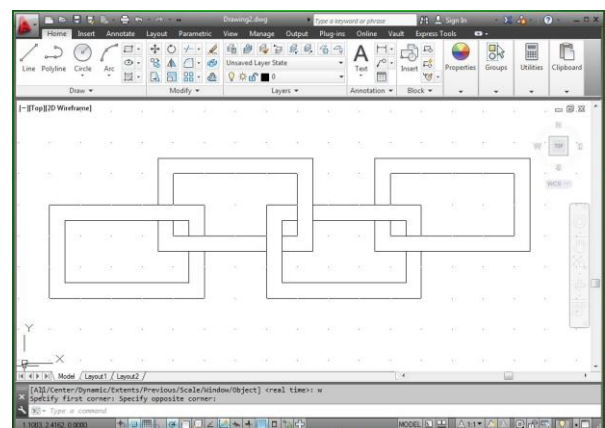

5. Finish the drawing properly by zooming to full limits (All). Always leave and save your pictures as a full view. Remember Zoom?

- Command: Zoom (enter)
- A (enter)

6. Now we need to finish this off with a border, title block and some text.

([Student Video #9](#))

Border

- Draw lines to create a border. Start at .5, .5 Make the border box 10 wide and 7.5 high. Which coordinate entry command will allow you to do this correctly?

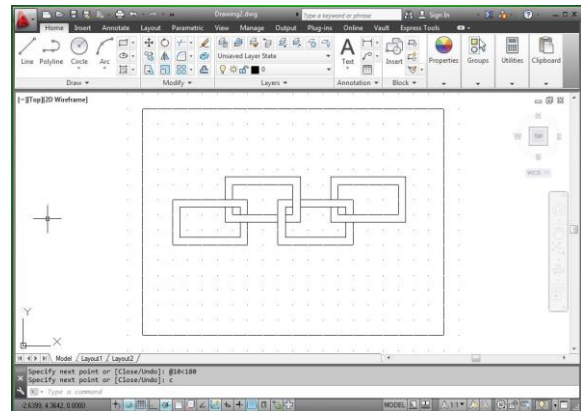

Title Block

- Offset the bottom line 0.5 for the title block.
- Next Draw 2 vertical lines one at 3.5,5 and the other at 8,.5. Which coordinate entry is the quickest?

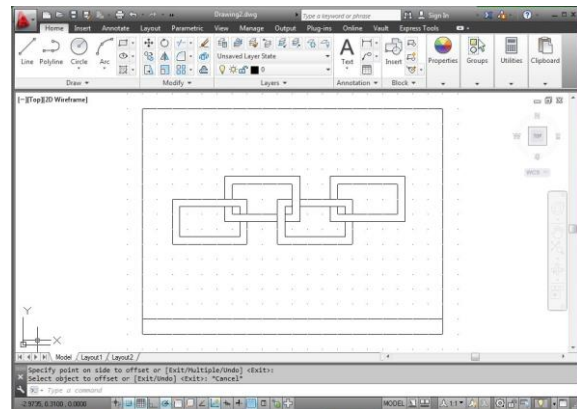

Now use the text command to fill in the Title Block. ([Student Video #10](#))

- Command: text (enter)
- Pick the point you want to start at. Don't worry about in not being

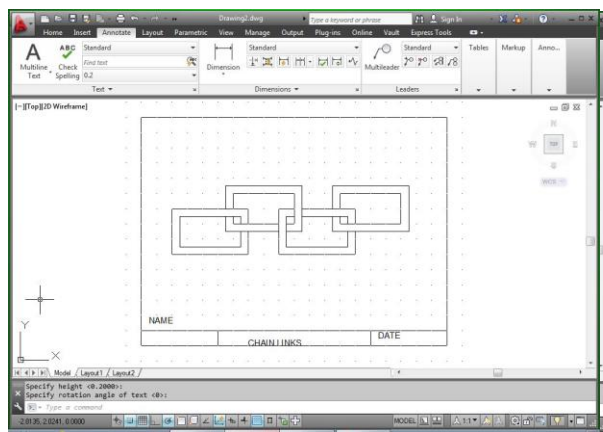

where you want it. We will move it after.

- Height of Text <.20> (enter) Rotation angle of text: <0> (enter)
- Now, type in the text you want in CAPITAL LETTERS.
- Press enter twice to exit the command
- Repeat this command sequence for each of the title block entries below.

Now that you have the text entered. You are going to move them into position. The problem is the snap setting won't let you centre them, so you have to change it.

- Command: snap (enter)05 (enter)
- Command: move (enter) pick one of your texts (enter)
- Use your mouse to move your text to where you want it so it is centred in the box
- Repeat the command sequence for the other two texts so they are centred in the appropriate spots as shown below.

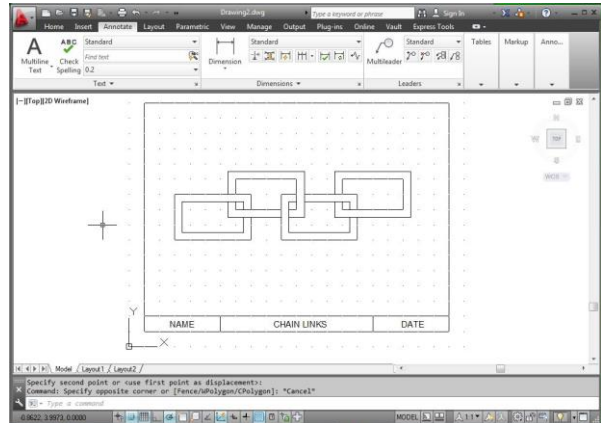

Printing the Drawing ([Student Video #11](#))

The drawing is now ready to be printed. When you go to print, first you have to make sure that the correct printer is selected, second that the paper and drawing orientation are set to the correct layout (landscape in this case), third that your Print area is set to extents and Print scale is set to 1:1