

Rafters Length, Layout, Cutting

- 1) **Measure the width of your building.** Use a tape measure to measure the entire width of your building. Measure as precisely as possible. Making these measurements 2 or 3 times is a good way to ensure accuracy.

It should be exactly 48"

Write this measurement down

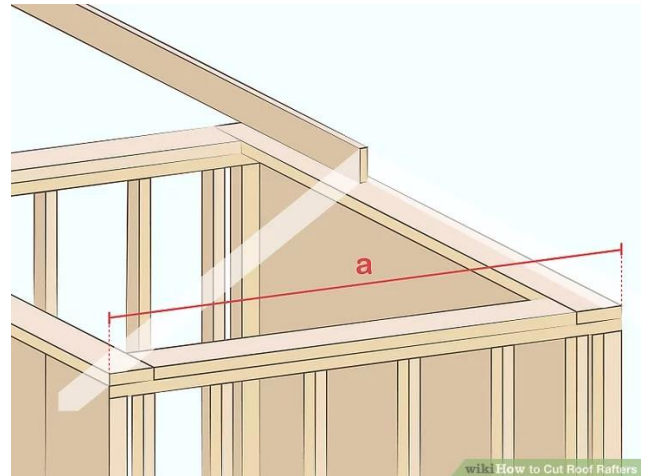

- 2) **Subtract the width of your ridge beam.** The ridge beam is the vertical piece of wood which will form the peak of the gable, and to which you'll fasten the rafters on either sides. Measure the width of the ridge beam: it should be 1 1/2" (2 x 4 or 2 x 6). Subtract this measurement from the width of your building.

You should get 46 1/2"

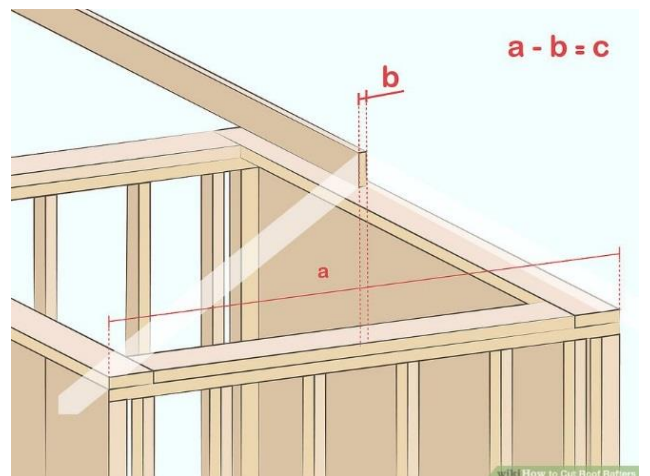

- 3) **Divide the adjusted width measurement by 2 to get the "Run".** Since each individual rafter will only span half of the building's width (minus the width of the ridge beam), divide the adjusted width measurement in half.

$$46 \frac{1}{2} / 2 = 23 \frac{1}{4}$$

The final measurement is referred to as the "run" of a building. Write the run measurement down alongside the other measurements.

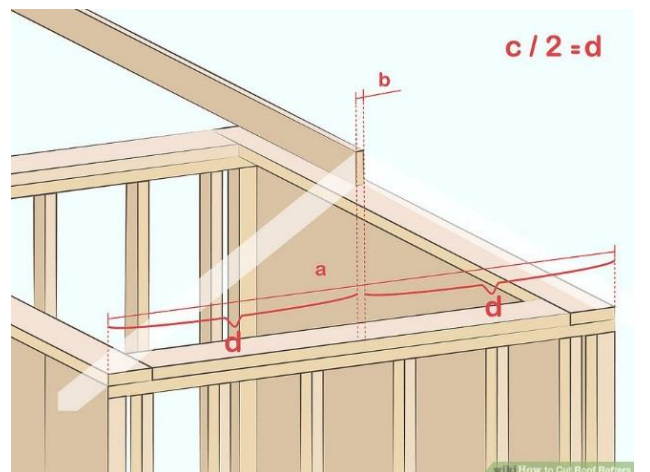

- 4) **Roof pitch.** The pitch of the roof is a ratio: the number of inches that the roof rises vertically for every foot of roof. This is a way of measuring the degree of steepness of the roof. If the roof rises 5 inches for every 1 foot, its pitch would be written as 5/12.

We are going to use a Roof pitch of 5/12

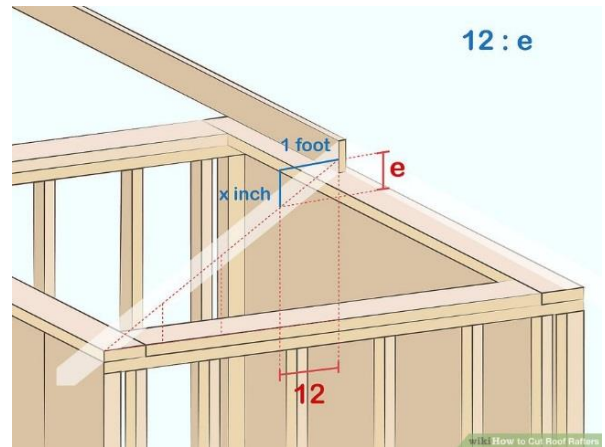

- 5) **Calculate the rise of your roof.** The “rise” is the vertical measurement that indicates how tall the roof will be at its highest point above the walls of the building. The rise is the exact height of the ridge beam.

$$\frac{\text{Rise}}{\text{Run}} = \frac{5}{12} = \frac{x}{23 \frac{1}{4}''}$$

$$12x = 116 \frac{1}{4}''$$

$$x = 116 \frac{1}{4}'' / 12$$

$$x = 9 \frac{11}{16}''$$

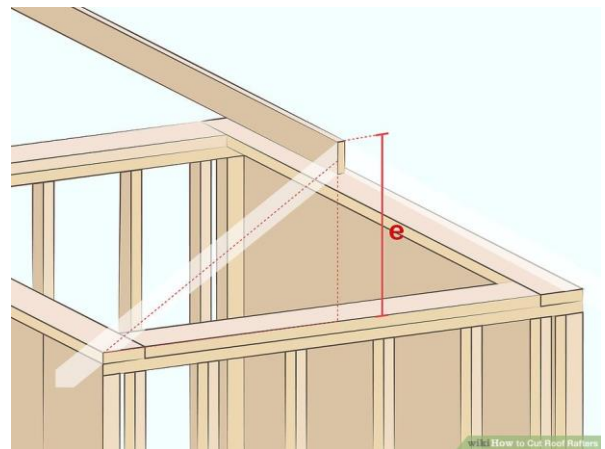

- 6) **Determine the line length of each rafter.** To calculate the “line length” you use Pythagoras' theorem. Using the Run (23 ¼”) from #3 above and the total rise (9 11/16”) from #5 above solve for the “Line Length” or diagonal length of the rafter.

$$a^2 + b^2 = c^2$$

$$\text{Rise}^2 + \text{Run}^2 = \text{Line Length}^2$$

$$9.6875^2 + 23.25^2 = \text{Line Length}^2$$

$$\sqrt{93.85 + 540.56} = \text{Line Length}$$

$$25.1875 = \text{Line Length}$$

$$25 \frac{3}{16}'' = \text{Line Length}$$

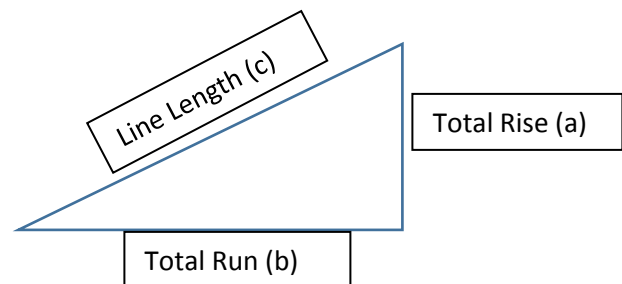

Making the Plumb Cut Line

- 1) **Fix stair gauges on the framing square to mark the pitch.** So, if the pitch of your roof is 5/12, place one stair gauge on the vertical part of the framing square (the “tongue”) at the **5 inch** mark, and place one stair gauge on the horizontal part of the framing square (the “body”) at the **12 inch** mark. This will give the framing square the angle you need to make the ridge cut.



- 2) **Mark the plumb cut Line at the top of the rafter.** The plumb (or ridge) cut is made at the top of the rafter. Choose which end of your rafter you want to be the top. Set the framing square on top of the rafter beam, with the tongue facing the top of the rafter. Then, use a pencil to trace the outside edge of the framing square’s tongue.

Draw the line at the edge of the board. This will be the correct angle for the rafter to lay flat against the ridge beam.

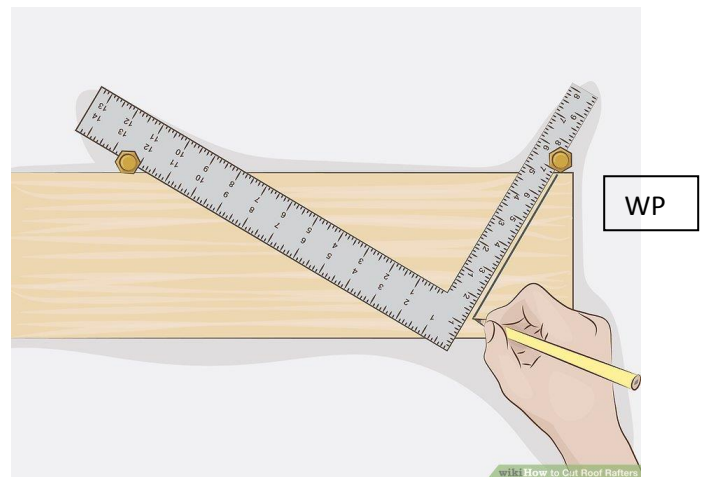

Measuring and Marking the Birdsmouth and Tail Cuts

- 1) **Measure the diagonal of the rafter.** Start this measurement from the top (the long end) of the cut you just made. When the rafter is installed, this top/long end will be at the peak of the ridge beam. Hook your tape measure on to the rafter, and measure the line length of the rafter that you calculated earlier (25 3/16"). Use your pencil to mark the length directly on the rafter.



The "line Length" or diagonal measurement is the full length of the rafter, minus the overhang. Measuring the "line length" or diagonal length will allow you to make the tail and bird's mouth cuts in the correct locations.

- 2) **Position the framing square to make the birdsmouth.** Align the framing square so that the stair gauge or **5 inch mark** on the tongue of the framing square is on the pencil mark you made to indicate the full diagonal length of the rafter. Hold the long end of the framing square so that the other stair gauge or **12 inch mark**, is also resting against the rafter; this will ensure that you mark the tail cut at the correct angle.

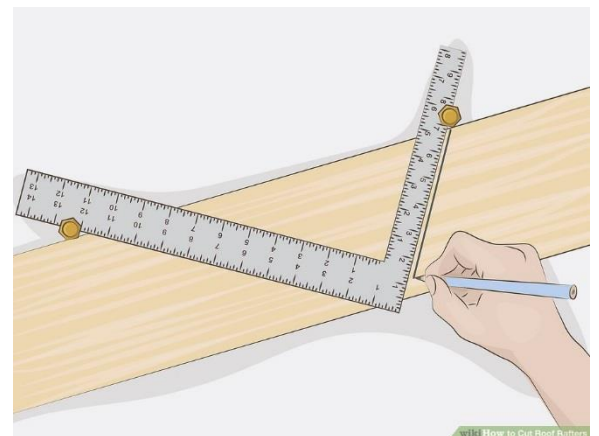

Use your pencil to trace the full length of the tongue along the width of the rafter.

- 3) **Determine the depth of the birdsmouth cut.** This is relatively simple: measure the full width of the outside wall. For most buildings, the birdsmouth cut is 4 inches deep: the width of the 2x4 used to frame the outer wall measures 3 1/2" inches and the outside sheathing measure 1/2 inch.

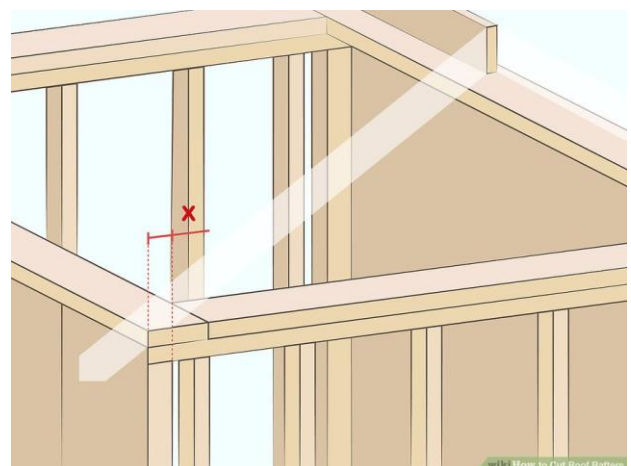

Sheathing is the term used for the board or panel that forms the outer surface of a building.

- 4) **Position the body of the framing square on the rafter.** Use the body (long side) of the framing square. Rotate it 180° from how you've been using it (so the right angle is pointing up). Set it so that the 8-inch mark on the body of the framing square intersects the line for the tail cut. This will provide a 4 in birdsmouth cut. Use your pencil to trace this line onto the wood.

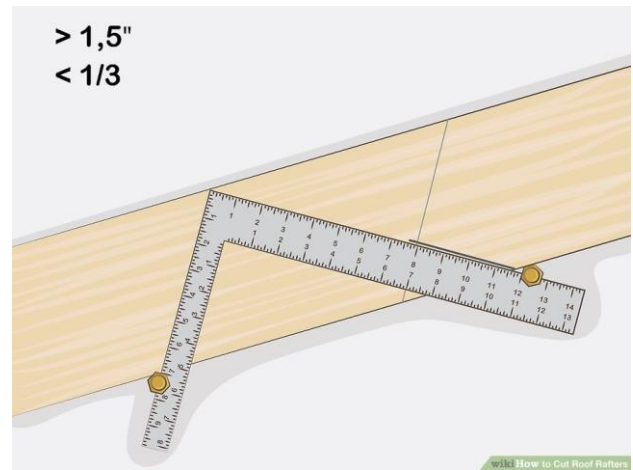

If your bird's mouth cut is not 4 inches deep, slide the framing square to shorten or lengthen the length of the cut accordingly. The rule for a birdsmouth is that it should be 1/3 of the width of the wood you are working with. So, if you are using a 2 x 4 as a rafter, the birdsmouth depth should be just under 1 1/4" in depth.

- 5) **Measure the rafter overhang.** If, for example, you want the rafter to overhang the edge of your building by 6 inches, measure this now. Keep the framing square in the position that it was set in to measure the birdsmouth cut. Slide the framing square until the **6 inch** mark intersects the line you've marked for the birdsmouth cut.

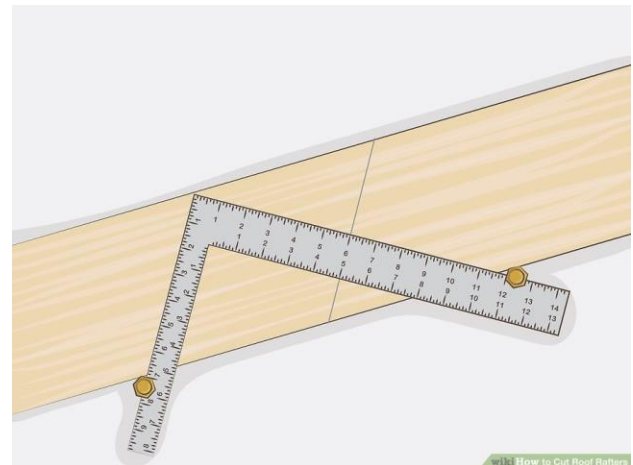

The final Line length of your rafter is now 31 3/16"

- 6) **Trace the tail cut.** Keep the framing square in the same position, and use your pencil to trace the **5 inch mark** on the tongue (short side) along the surface of the rafter. The stair gauges will hold the framing square at the proper angle.) This will mark the tail cut: the very end of your rafter, with the 6 inches overhang built in and the birdsmouth cut neatly marked.

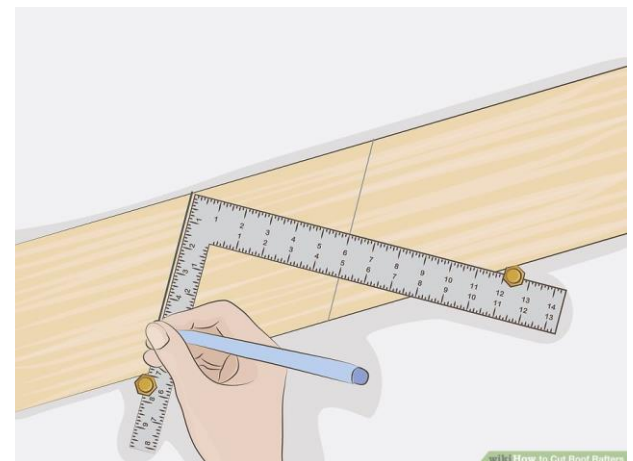

Now all that's left is to cut the rafter accordingly.

Making the Plumb Cut, Birdsmouth and Tail Cuts

- 1) **Saw along the line you've marked that indicates the plumb cut.** Using a circular saw cut the rafter along the line you've just marked. Be sure to follow the line exactly, or you'll have an uneven plumb cut.

Clamp the rafter to a workbench or sawhorses



Alternately you can use a mitre saw to cut the Plumb Cut Line to get a more accurate cut. You can use a speed square to find the angle.

- a) Pivot the speed square to match the Plumb Cut Line
- b) For the common rafter layout it should read 5 and in a roof pitch of 5:12
- c) Read the degrees along the bottom edge

You should get approx 22.5 degrees

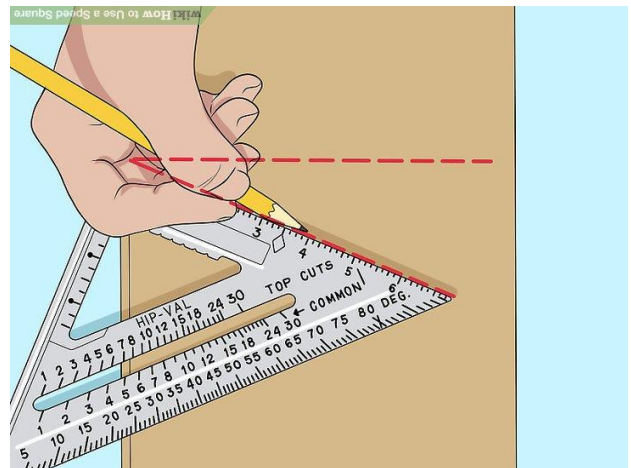

- 2) **Saw along the line you marked for the birdsmouth cut.** Be very precise with this cut since, unlike the plumb cut, you can't saw all the way through the board. Carefully follow the lines you've marked for the tail cut so that it maintains the specific measurements and angles. ^[20]

For added stability when making the birdsmouth and tail cuts, use C-clamps to clamp the rafter to a workbench or sawhorses.



- 3) **Saw along the line you marked for the tail cut.** Using your handsaw or circular saw, cut precisely along the line that you've marked for the tail cut. The excess rafter material will fall off as you complete this cut, leaving you with the finished rafter.



- 4) **Repeat the process for your other rafters.** At this point, you've cut 1 roof rafter. All roof rafters should be identical, so follow the same steps to measure the plumb cut, tail cut, and birdsmouth cut.

The number of rafters needed will be determined by the length of your roof. Rafters are commonly spaced about 24 inches (61 cm) apart.

Keep in mind that you'll always need an even number of rafters.

