

Introduction to Arduino

Ultrasonic

Mark /10

Note: Marks will be taken off for messy breadboarding

1. In this lab you are going to use an HC-SR04 Ultrasonic Range Finder to sense the distance to an object. The feedback will be sent to the Serial Monitor in the Arduino Software. You will also use an RGB LED as feedback during the lab.
2. The RGB LED that you will be using has 4 legs. It has a Common Anode (longest leg) which connects towards the positive through a resistor and then 3 other legs, one for each colour (red, green, blue) as shown below.

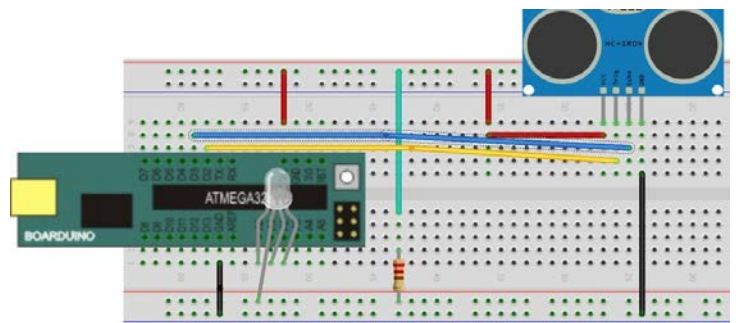
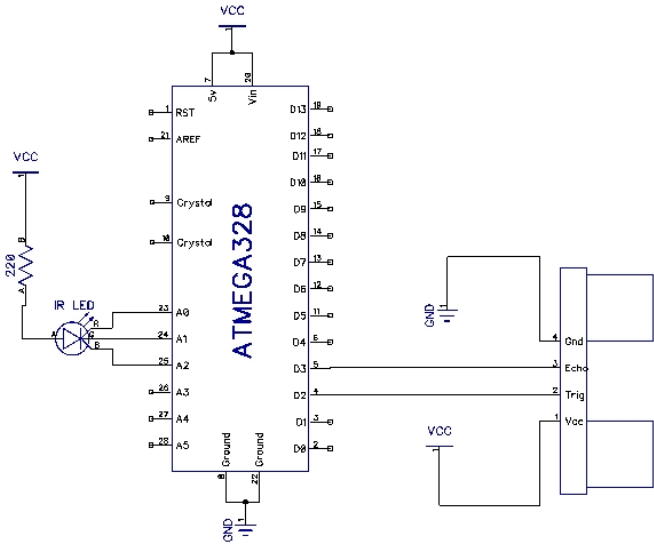
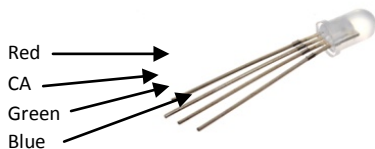

3. Breadboard the lab and then copy the code from the right into the Arduino Software and then upload it. Start the **“Serial Monitor”** under the **“Tools”** drop down menu.
4. The ultrasonic sensor measures the distance you are to a reflective surface by emitting high-frequency sound waves and measuring the time it takes for the **“echo”** to be picked up by the detector. It works between 1inch and 120inches (3cm to 3m). You know it is working when the value in inches changes on the **“Serial Monitor”** screen as you move your hand closer and farther away from the sensor.

Show the teacher the working lab and code.

5. Modify your circuit and the code so that when the range is MORE than 15 inches a **“Green”** LED is on, when the range is

```
int pingPin = 2; //Trigger
int inPin = 3; //Echo

void setup() {
  Serial.begin(9600);
  pinMode(pingPin, OUTPUT);
  pinMode(inPin, INPUT);
}

void loop()
{
  long duration, inches;

  digitalWrite(pingPin, LOW);
  delayMicroseconds(2);
  digitalWrite(pingPin, HIGH);
  delayMicroseconds(10);
  digitalWrite(pingPin, LOW);

  duration = pulseIn(inPin, HIGH);

  inches = microsecondsToInches(duration);

  Serial.println(inches);
  Serial.println("in");
  delay(50);
}

long microsecondsToInches(long microseconds)
{
  return microseconds / 74 / 2;
}
```

BETWEEN 10 inches and 15 inches the “Blue” LED is on and when it is LESS than 10 inches the “Red” LED comes on. To do this;

- Make sure you define the RGB LED in setup so it will work (there are 3);

```
Pinmode (A0, OUTPUT);
```

- Use IF statements (where do they go in the code?);

```
if (inches > 15) digitalWrite (A0, LOW);
```

*Hint: use the following line of code. A double “&&” means **AND**. Therefore, if the value is greater than (>) 10 **AND** the value is also less than 15, turn the light on.*

```
if (inches > 10 &&inches < 15) digitalWrite(A0, LOW);
```

&& = Logical AND
|| = Logical OR
!! = NOT

As a reference
== (equal to)
!= (not equal to)
< (less than)
> (greater than)
<= (less than or equal to)
>= (greater than or equal to)

6. Finally, add a piezo buzzer (you choose the output pin) that beeps every half second when you are between 10 - 15inches and beeps every quarter of a second when the distance is less than 10inches.

Show the teacher the working lab and code.