

Day 1

 Practice (Source: <https://openupresources.org/math-curriculum/>)

 Select **all** the true equations.

A. $5 + 0 = 0$

B. $15 \cdot 0 = 0$

C. $1.4 + 2.7 = 4.1$

D. $\frac{2}{5} \cdot \frac{5}{9} = \frac{7}{12}$

E. $4\frac{2}{3} = 5 - \frac{1}{3}$

 Equivalent Ratios (Source: <https://www.openmiddle.com/>)

Using each of the digits 0-6 only once, make two equivalent ratios (also known as a proportion).

$$\frac{\square}{\square \square} = \frac{\square \square}{\square \square}$$

 Eightfold (Source: <https://playwithyourmath.com/>)

Try this challenge!

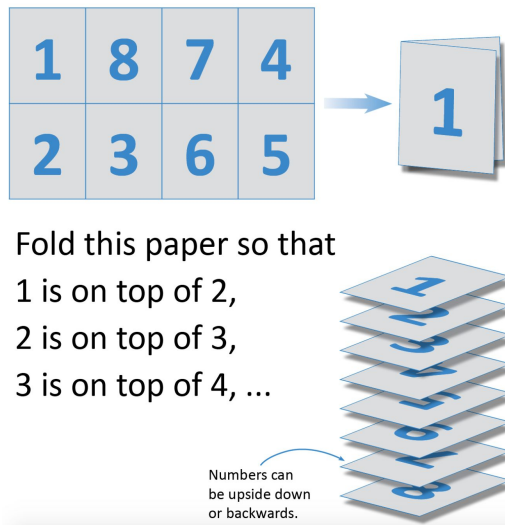

Day 2

Expression (Source: <https://openupresources.org/math-curriculum/>)

Mai's water bottle had 24 ounces in it. After she drank x ounces of water, there were 10 ounces left. Select all the equations that represent this situation.

- A. $24 \div 10 = x$
- B. $24 + 10 = x$
- C. $24 - 10 = x$
- D. $x + 10 = 24$
- E. $10x = 24$

Odd Pig Out Game (Source: mathforlove.org)

Roll two dice and multiply them. You can keep rolling as long as the product is even. If the product is odd, you lose all unbanked points for that turn, and pass the dice. Play to 500.

Fraction Talk (Source: <http://fractiontalks.com/>)

Shade in one of the regions in this square. What fraction of the big square did you shade? Explain.

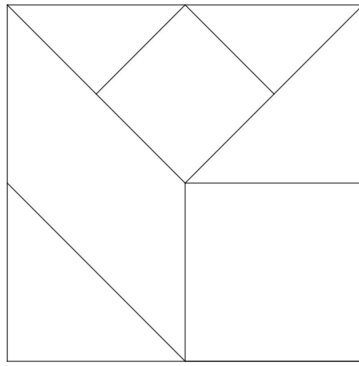

Day 3

Decimal Addition (Source: <https://www.openmiddle.com/>)

Use the digits, 0 through 9, without repeats, to complete the equation below:

$$\begin{array}{r}
 \square \square . \square \\
 + \square \square . \square \\
 \hline
 \square \square . \square
 \end{array}$$

Which One Doesn't Belong? (Source: wodb.ca)

Choose a number in this picture that you don't think belongs with the rest. Explain why. Can you pick another number and give a different reason?



Word Problem (Source: <https://openupresources.org/math-curriculum/>)

The daily recommended allowance of vitamin C for a sixth grader is 45 mg. 1 orange has about 75% of the recommended daily allowance of vitamin C. How many milligrams are in 1 orange? If you get stuck, consider using the double number line.

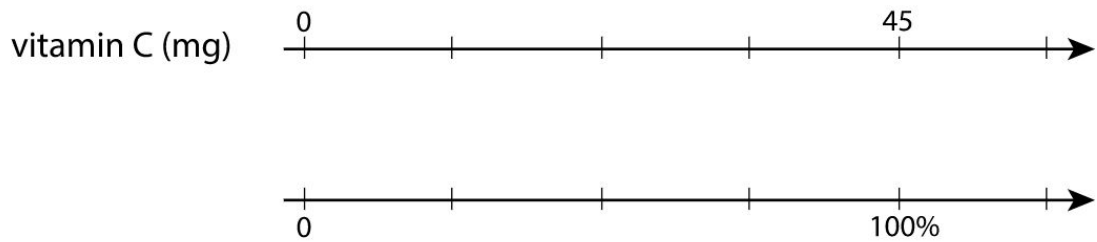

Day 4

Percent Problems (Source: <https://openupresources.org/math-curriculum/>)

There are 90 kids in the band. 20% of the kids own their own instruments, and the rest rent them.

- How many kids own their own instruments?
- How many kids rent instruments?
- What percentage of kids rent their instruments?

One Big Factor Family (Source: <https://playwithyourmath.com/>)

Imagine that each number has a family.

- Its children are its factors that are not equal to itself.
- Some numbers have grandchildren...
- ... and great-grandchildren
- There are four 1s in the 8's family

How many 1s are in the 72's family?

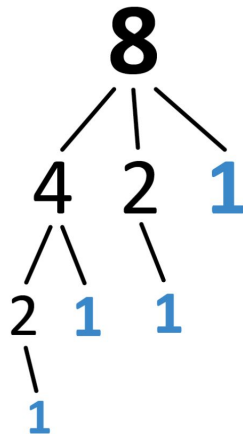

Visual Pattern (Source: visualpatterns.org)

Below is a pattern of trees in stages 1-3 below.

- A. Draw what you think stage 4 might look like.
- B. Draw or describe what you think stage 10 might look like.
- C. Label how many trees are in each stage.
- D. Try to write an expression to describe the relationship between the stage number n and the number of trees T .

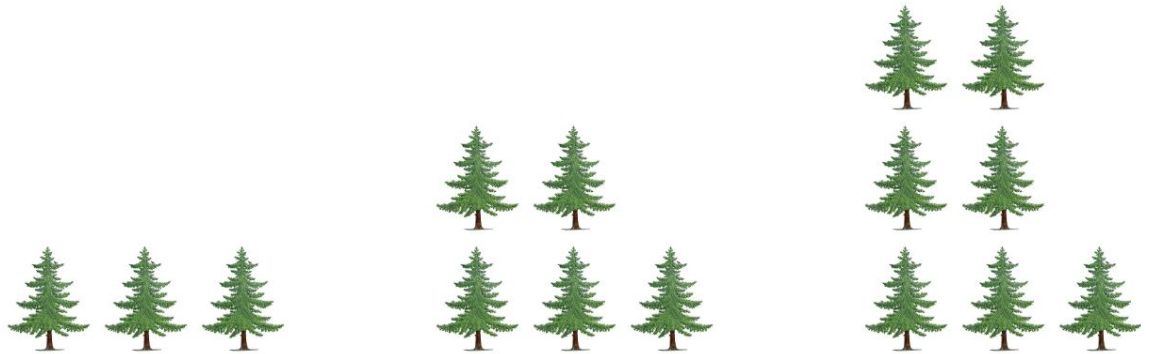

Day 5

Balance (Source: <https://openupresources.org/math-curriculum/>)

Here is a balanced hanger.

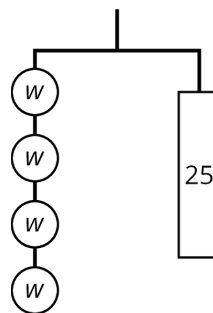

- A. Write an equation representing this hanger.
- B. Find the weight of one circle. Show or explain how you found it.

Writing Equations (Source: <https://openupresources.org/math-curriculum/>)

Write an equation to represent each hanger.

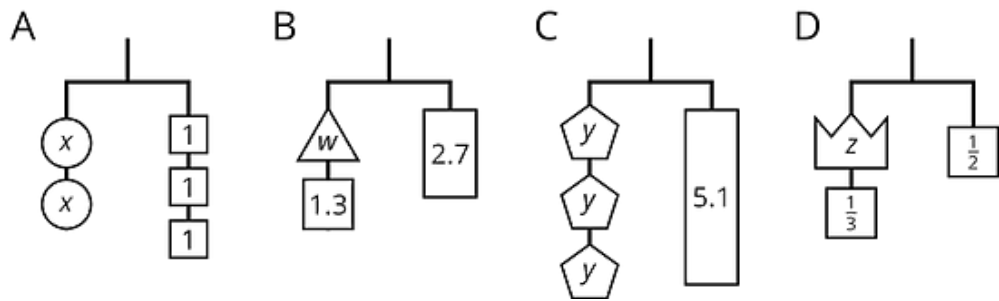

Would You Rather (Source: <https://www.wouldyourathermath.com/>)

Whichever option you choose, justify your reasoning with mathematics.

Work as a server at Restaurant A
OR
 Work as a server at Restaurant B?

Restaurant A	Restaurant B
\$18 per hour No tipping allowed (meals range from \$8 to \$25 each)	\$10.50 per hour Tipping encouraged (meals range from \$8 to \$25 each)

wouldyourathermath.com

Day 1

Equations (Source: <https://openupresources.org/math-curriculum/>)

Select *all* the equations that describe each situation and then find the solution.

A. Kiran's backpack weighs 3 pounds less than Clare's backpack. Clare's backpack weighs 14 pounds. How much does Kiran's backpack weigh?

i. $x + 3 = 14$

ii. $3x = 14$

iii. $x = 14 - 3$

iv. $x = 14 \div 3$

B. Each notebook contains 60 sheets of paper. Andre has 5 notebooks. How many sheets of paper do Andre's notebooks contain?

i. $y = 60 \div 5$

ii. $y = 5 \cdot 60$

iii. $\frac{y}{5} = 60$

iv. $5y = 60$

Order of Operations (Source: <https://www.openmiddle.com/>)

Using the digits 1 to 5, at most one time each, place a digit in each box to create an expression with the largest possible value.

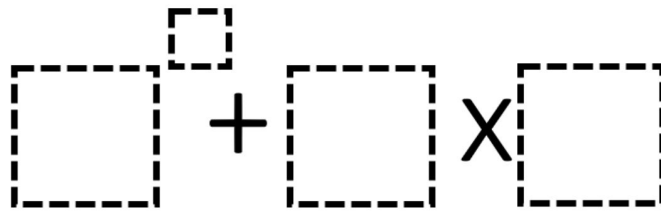

Scale (Source: <https://brilliant.org/>)

What weight will the fourth scale display?



Day 2

Equations (Source: <https://openupresources.org/math-curriculum/>)

Solve each equation.

A. $2x = 5$

B. $y + 1.8 = 14.7$

C. $6 = \frac{1}{2}z$

D. $3\frac{1}{4} = \frac{1}{2} + w$

E. $2.5t = 10$

Gold Chest (Source: <https://brilliant.org/>)

Exactly one of these chests contains gold, but only one of the four statements is true. Which chest must contain the gold?

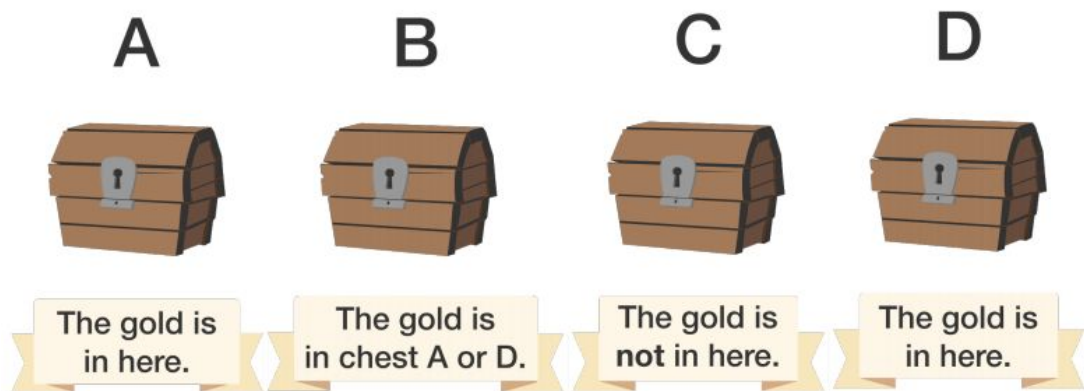

Lots of Lollies (Source: <https://wild.maths.org/>)



Frances and Rishi were given a bag of lollies. They shared them out evenly and had one left over.

Just as they had finished sharing them, their friends Kishan, Hayley and Paul came along. They wanted some lollies too so the children shared them out again between all of them. This time they had two lollies left over.

How many lollies could there have been in the bag?

Day 3

Which One Doesn't Belong? (Source: wodb.ca)

Choose a shape in this picture that you don't think belongs with the rest. Explain why. Can you pick another shape and give a different reason?

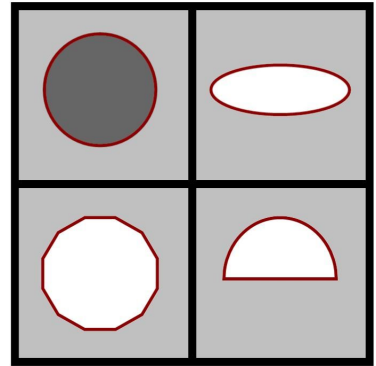

Solving One-Step Equation (Source: <https://www.openmiddle.com/>)

Use the digits 1 to 9, at most one time each, to create an equation where x has the greatest possible value.

$$\square\square + x = \square\square$$

Product (Source: <https://openupresources.org/math-curriculum/>)

Find each product.

A. $(21.2) \cdot (0.02)$

B. $(2.05) \cdot (0.004)$

Day 4

Even and Odd (Source: <https://brilliant.org/>)

Can an even number, divided by another even number, times another even number ever equal an odd number? What are your thoughts?

$$\frac{\text{Even}}{\text{Even}} \times \text{Even} = \text{Odd}$$

Equations (Source: <https://openupresources.org/math-curriculum/>)

Solve each equation.

A. $4x = 32$

B. $4 = 32x$

C. $10x = 26$

D. $26 = 100x$

Visual Pattern (Source: visualpatterns.org)

Below is a pattern of pineapples in stages 1-3 below.

- A. Draw what you think stage 4 might look like.
- B. Draw or describe what you think stage 10 might look like.
- C. Label how many pineapples are in each stage.
- D. Try to write an equation to describe the relationship between the stage number n and the number of pineapples P .

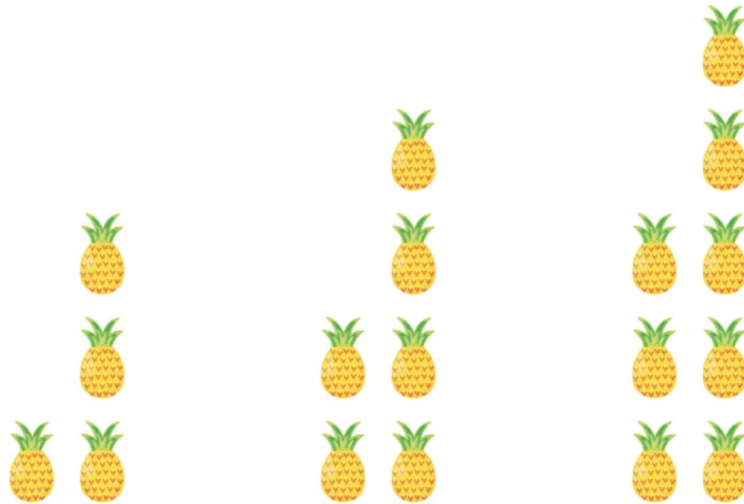

Day 5

Fundraiser (Source: <https://openupresources.org/math-curriculum/>)

Write as many mathematical expressions or equations as you can about the image. Include a fraction, a decimal number, or a percentage in each.

FUNDRAISER

OUR GOAL:
\$250,000

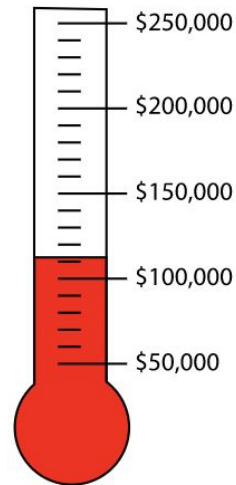

Paint Mixture (Source: <https://openupresources.org/math-curriculum/>)

In a lilac paint mixture, 40% of the mixture is white paint, 20% is blue, and the rest is red. There are 4 cups of blue paint used in a batch of lilac paint. *If you get stuck, consider using a tape diagram.*

- A. How many cups of white paint are used?
- B. How many cups of red paint are used?
- C. How many cups of lilac paint will this batch yield?

Would You Rather (Source: <https://www.wouldyourathermath.com/>)

Would you rather buy one 8-lb container of ice cream for \$24.56, or two 3-lb 11-oz containers of ice cream for \$23.60?

Whichever option you choose, justify your reasoning with mathematics.

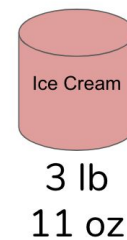
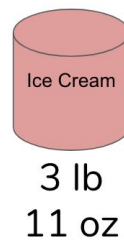
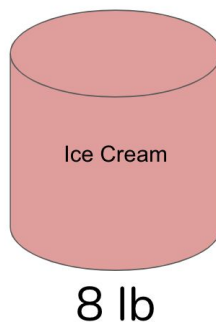

Day 1

 Writing Equations (Source: <https://openupresources.org/math-curriculum/>)

Here are some balanced hangers. Each piece is labeled with its weight.

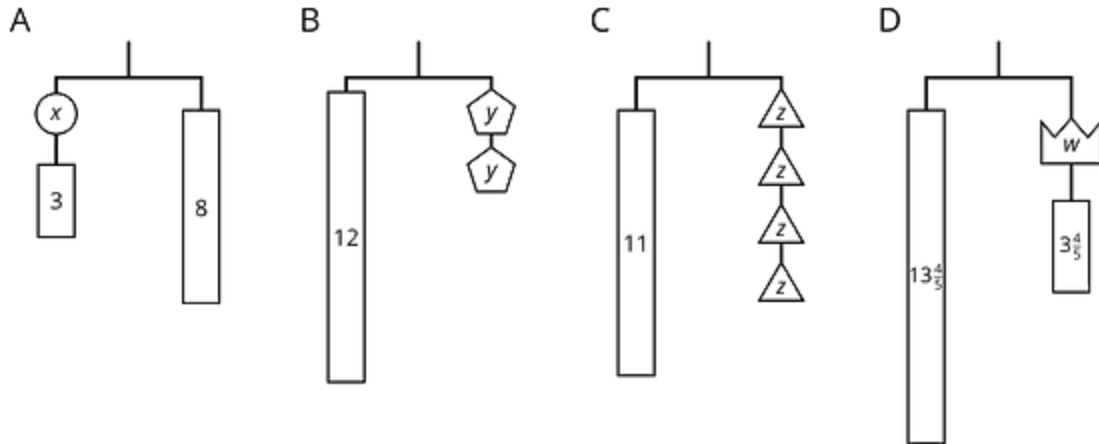

For each diagram, write an equation and find the weight of a piece with a letter.

 Fraction of an Amount (Source: <https://www.openmiddle.com/>)

Using the digits from 1 to 9, at most once, make as many true statements as possible.

$$\frac{\square}{\square} \text{ of } \square\square = \square\square$$

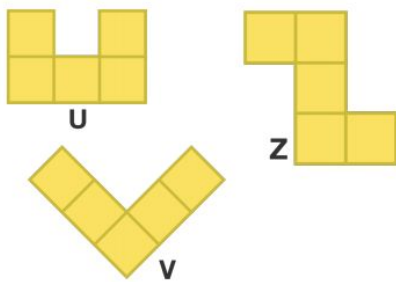
 Pentominoes (Source: <https://brilliant.org/>)

Using all three of the pentominoes to the left, they can be assembled into one of the shapes below (rotations and reflections are allowed). Which one?

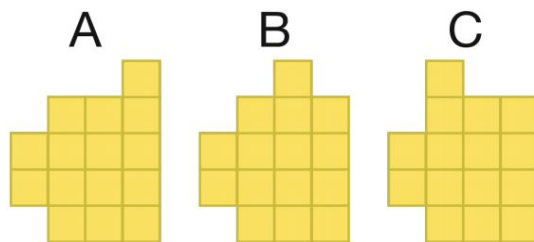

Day 2

Equations (Source: <https://openupresources.org/math-curriculum/>)

Match each equation to one of the diagrams.

a. $12 - m = 4$

b. $12 = 4m$

c. $m - 4 = 12$

d. $\frac{m}{4} = 12$

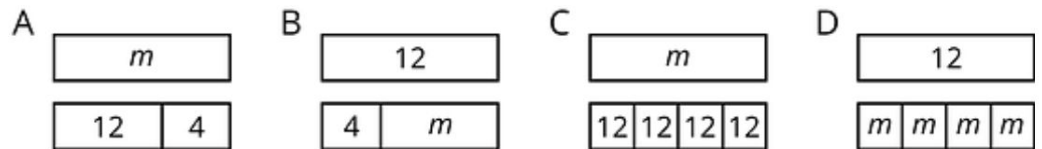

Gold Chest (Source: <https://brilliant.org/>)

What is the value of **A**?

$$\begin{array}{r} \\ \\ \hline 1 \end{array} \begin{array}{r} A \\ A \\ 3 \\ 8 \end{array} \begin{array}{r} B \\ B \\ 8 \\ 8 \end{array}$$

Fraction Talk (Source: mathforlove.org)

What fraction of the big rectangle is each of the shaded parts?

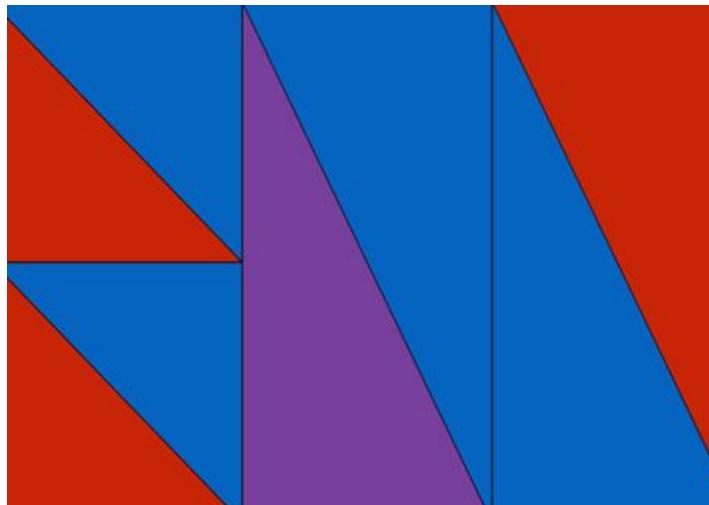

Day 3

Which One Doesn't Belong? (Source: wodb.ca)

Choose a square in this picture that you don't think belongs with the rest. Explain why. Can you pick another square and give a different reason?

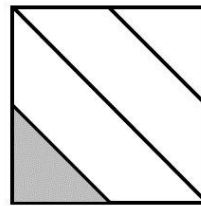
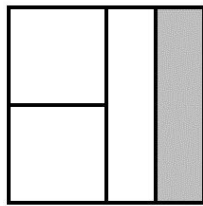
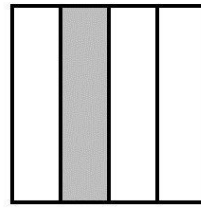
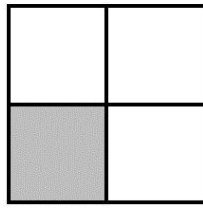

Adding Multiple Decimals (Source: <https://www.openmiddle.com/>)

Use the digits 0 to 9, at most one time each, to fill in the boxes so that the sum is as close to 10 as possible.

$$\square.\square + \square.\square + \square.\square\square$$

Product (Source: <https://openupresources.org/math-curriculum/>)

A trash bin has a capacity of 50 gallons. What percentage of its capacity is each of the following? Show your reasoning.

- 5 gallons
- 30 gallons
- 45 gallons
- 100 gallons

Day 4

Puzzle (Source: <https://brilliant.org/>)

If you arrange all five of the tiles below to make the statements in both boxes true, which box must the tile "3" be in?

Note: Product is the result of multiplication.

Wyatt

"The product of my two tiles is odd."

Xandra

"The product of my three tiles is smaller than the product of Wyatt's tiles."

1

2

3

4

5

Visual Pattern (Source: visualpatterns.org)

Below is a pattern of cars in stages 1-3 below.

- A. Draw what you think stage 4 might look like.
- B. Draw or describe what you think stage 10 might look like.
- C. Label how many cars are in each stage.
- D. Try to write an equation to describe the relationship between the stage number n and the number of cars C .

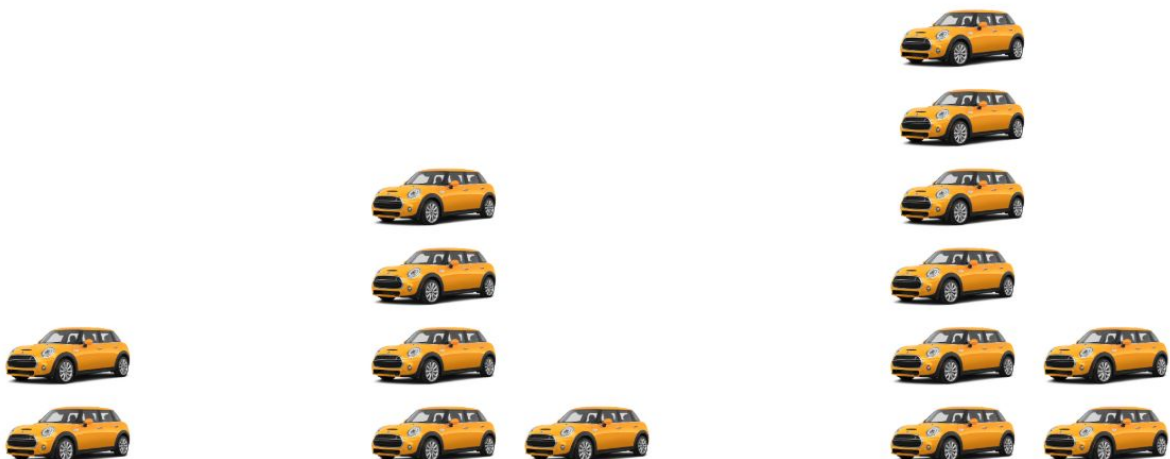

Percents Practice (Source: <https://openupresources.org/math-curriculum/>)

Noah raised \$54 to support the animal shelter, which is 60% of his fundraising goal.

1. Write an equation to represent the situation.
2. What is Noah's fundraising goal? Show or explain how you found it.
3. A crew has paved $\frac{3}{4}$ of a mile of road. If they have completed 50% of the work, how long is the road they are paving?

Day 5

Percent Of (Source: <https://openupresources.org/math-curriculum/>)

Answer each question. Show your reasoning.

- a. 20% of a is 11. What is a ?
- b. 75% of b is 12. What is b ?
- c. 80% of c is 20. What is c ?
- d. 200% of d is 18. What is d ?

Expressions (Source: <https://openupresources.org/math-curriculum/>)

Here is a list of expressions. Find any pairs of expressions that are equivalent. If you get stuck, try reasoning with diagrams.

$$a + 3$$

$$a \div \frac{1}{3}$$

$$\frac{1}{3}a$$

$$\frac{a}{3}$$

$$a$$

$$a + a + a$$

$$a \cdot 3$$

$$3a$$

$$1a$$

$$3 + a$$

Puzzle (Source: <https://www.solvemoji.com/>)

What is the value of the last row?

$$\text{📖} + \text{📖} + \text{📖} = 21$$

$$\text{📖} + \text{📖} \times \text{📖} = 238$$

$$\text{📖} + \text{📖} \times \text{📖} = 48$$

$$\text{📖} + \text{📖} \times \text{📖} = ?$$

Day 1

Story Problems (Source: <https://openupresources.org/math-curriculum/>)

For each story problem, write an equation to represent the problem and then solve the equation. Be sure to explain the meaning of any variables you use.

- A. Jada's dog was inches tall when it was a puppy. Now her dog is inches taller than that. How tall is Jada's dog now?
- B. Lin picked pounds of apples, which was 3 times the weight of the apples Andre picked. How many pounds of apples did Andre pick?

Fraction Division (Source: <https://www.openmiddle.com/>)

Use the digits 0 through 9, without repeats, to solve the problem below.

$$\frac{\square}{\square} \div \frac{\square}{\square} = \frac{\square \square}{\square}$$

Surface Area (Source: <https://brilliant.org/>)

27 unit cubes are packed together to create this $3 \times 3 \times 3$ cube. Each face of a unit cube has an area of 1. If all 8 of the corner cubes are removed, by how much will the surface area of the figure increase?

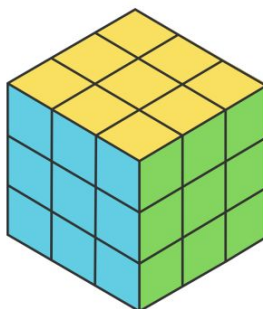

Day 2Distributive Property (Source: <https://openupresources.org/math-curriculum/>)

Select all the expressions that represent the area of the large, outer rectangle.

- A. $5(2 + 4)$
- B. $5 \cdot 2 + 4$
- C. $5 \cdot 2 + 5 \cdot 4$
- D. $5 \cdot 2 \cdot 4$
- E. $5 + 2 + 4$
- F. $5 \cdot 6$

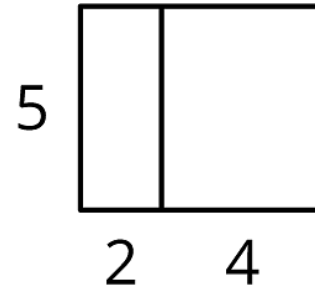
Puzzle (Source: <https://brilliant.org/>)

Arrange the six tiles below to make the statements in all three boxes true. When you're finished, which tile is in the same box as 5?

<p>Ren</p> <p>"The sum of my two tiles is even."</p>	<p>Sam</p> <p>"The sum of my two tiles is even."</p>	<p>Tamara</p> <p>"The product of my two tiles is 12."</p>
---	---	--

1	2	3	4	5	6
---	---	---	---	---	---

Fraction Talk (Source: mathforlove.org)

What fraction of the big rectangle is the region marked X?

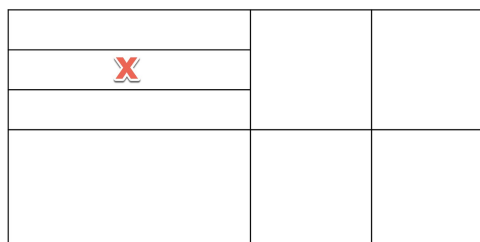

Day 3

Which One Doesn't Belong? (Source: wodb.ca)

Choose a number in this picture that you don't think belongs with the rest. Explain why. Can you pick another number and give a different reason?

$-\frac{1}{4}$	40%
$\frac{3}{2}$	$\frac{1}{6}$

Percent Of (Source: <https://www.openmiddle.com/>)

Using the digits 0 to 9 at most one time each, fill in the boxes to create a correct sentence:

$$\boxed{}\% \text{ of } \boxed{}\boxed{}\boxed{} = \boxed{}\boxed{}$$

Expressions (Source: <https://openupresources.org/math-curriculum/>)

Select **all** the expressions that are equivalent to $4b$.

A. $b + b + b + b$

B. $b + 4$

C. $2b + 2b$

D. $b \cdot b \cdot b \cdot b$

E. $b \div \frac{1}{4}$

Day 4

Triangles (Source: <https://brilliant.org/>)

Every small, shaded triangle in the design below is the same size. What is the side length of one of the small, shaded triangles?

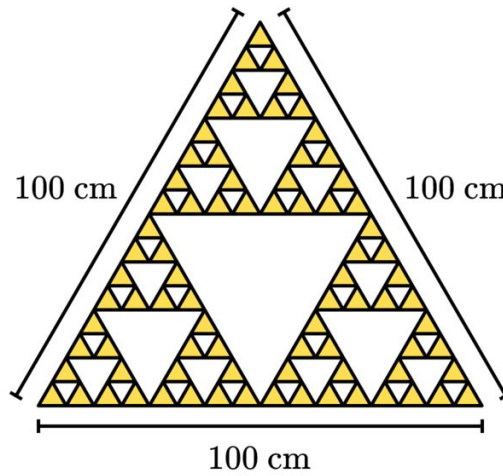

Visual Pattern (Source: visualpatterns.org)

Below is a pattern of cylinders in stages 1-3 below.

- A. Draw what you think stage 4 might look like.
- B. Draw or describe what you think stage 10 might look like.
- C. Label how many cylinders are in each stage.
- D. Try to write an equation to describe the relationship between the stage number n and the number of cylinders C .

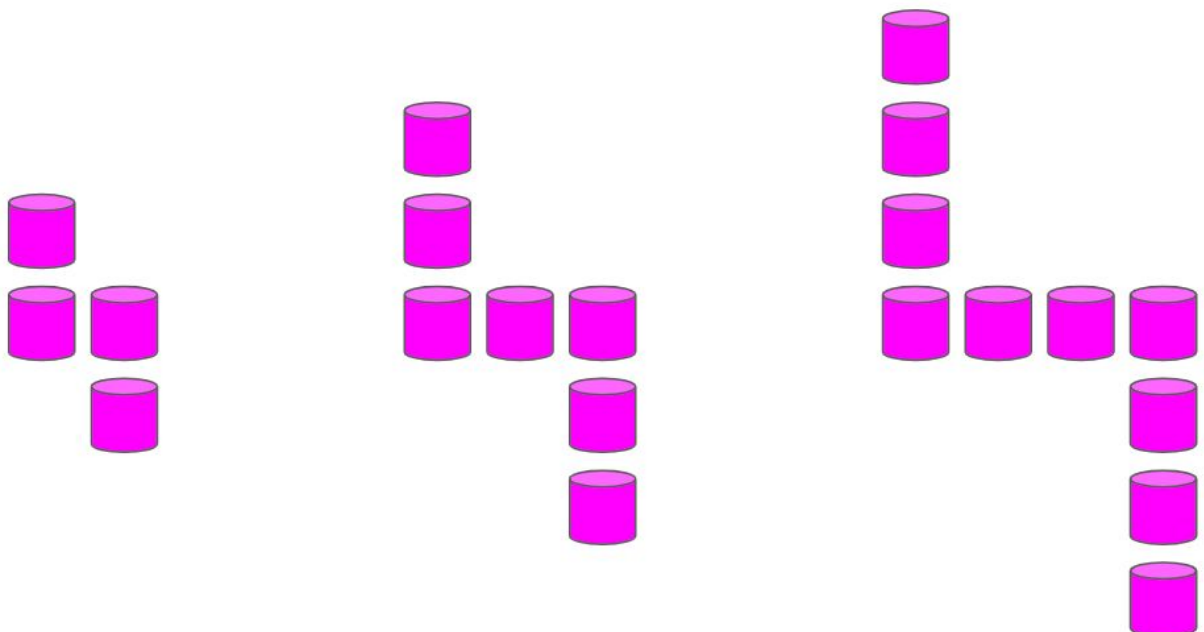

Solving Equations (Source: <https://openupresources.org/math-curriculum/>)

Solve each equation. Show your reasoning.

a. $111 = 14g$

c. $k + \frac{1}{3} = 5\frac{1}{8}$

e. $5.16 = 4n$

b. $13.65 = h + 4.88$

d. $\frac{2}{5}m = \frac{17}{4}$

Day 5

Exponents (Source: <https://openupresources.org/math-curriculum/>)

Select all the expressions that are equivalent to 3^4 .

A. 7

D. 81

B. 4^3

E. 64

C. 12

F. 9^2

Equations (Source: <https://openupresources.org/math-curriculum/>)

Decide whether each equation is true or false, and explain how you know.

a. $9 \cdot 9 \cdot 3 = 3^5$

b. $7 + 7 + 7 = 3 + 3 + 3 + 3 + 3 + 3 + 3$







c. $\frac{1}{7} \cdot \frac{1}{7} \cdot \frac{1}{7} = \frac{3}{7}$

d. $4^1 = 4 \cdot 1$

e. $6 + 6 + 6 = 6^3$

Puzzle (Source: <https://www.solvemoji.com/>)

What is the value of the last row?

	+		=	6		
+		+				
	+		=	9		
=		=				
7		8				
<hr/>						
	+		x		=	?