

Briggs & Stratton Engine Starting & Tuning

Engine Start & Tune

1. Secure an engine stand in a vise



2. Place engine on stand and secure with four bolts.



3. Fill engine oil to correct level.



Carburetor Setup

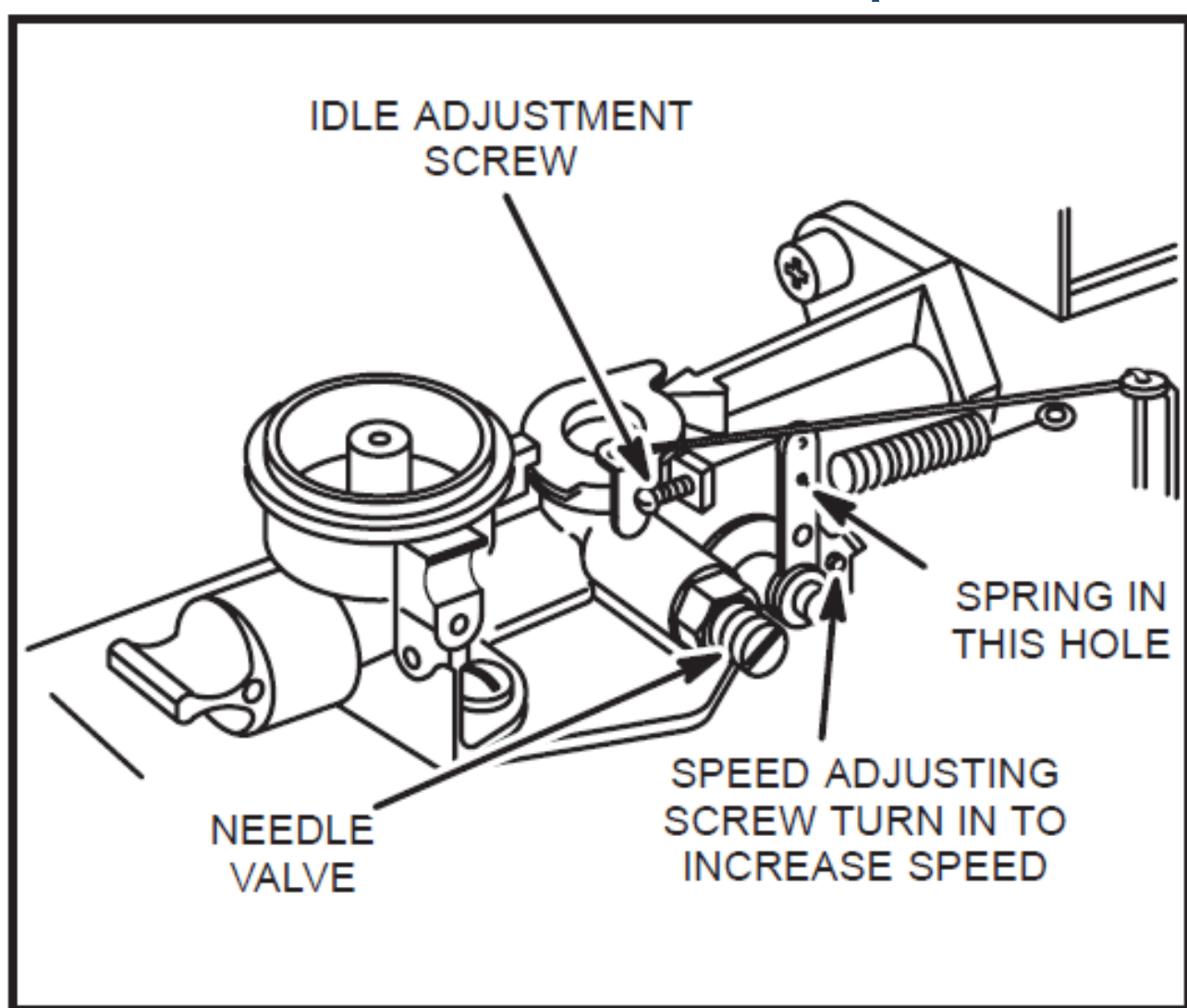

4. Make initial carburetor settings to the mixture screw.



Turn screw in (clockwise) until **lightly seated**, then back out 1 ½ turns.

4. Make initial carburetor settings to the idle speed adjusting screw.

1. Turn throttle valve fully counter-clockwise, then back out screw until space can be seen between it and its stop.
2. Turn in screw until it just touches its stop, from this point turn the screw in $1 \frac{1}{2}$ turns further.
3. Initial carb settings have now been achieved

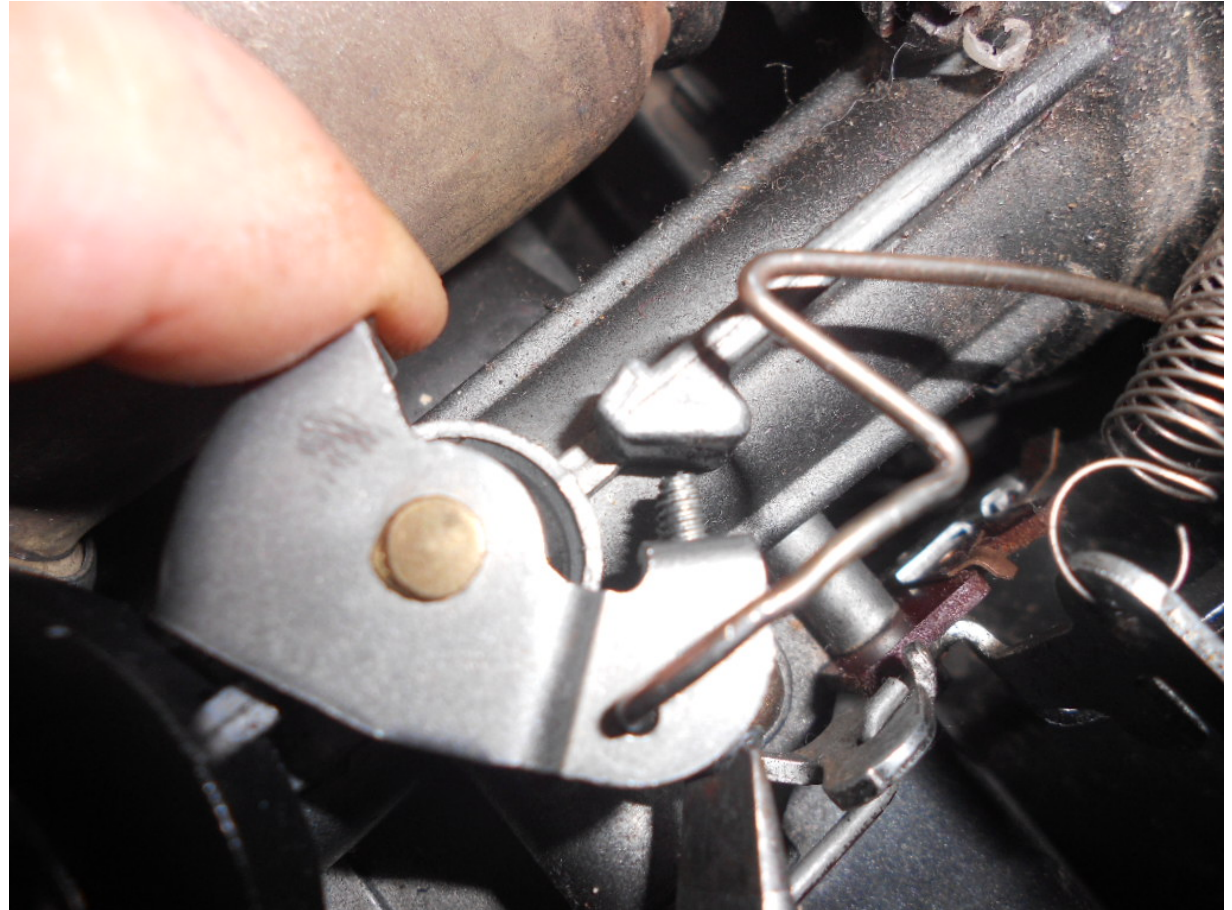

6. Outside, fill fuel tank with sufficient fuel to run approximately 10 min.



Make sure you have a tank gasket!

Submerge bottom of pick-up tube in 1 cm of fuel.

7. Apply choke valve and move speed control lever to full throttle position.



8. **OUTSIDE,** With engine secured in a vise. Start the engine and let it warm up.



Check behind you before pulling recoil starter!

8. Caution: When engine is running, and for some time afterward, the muffler will be extremely hot!

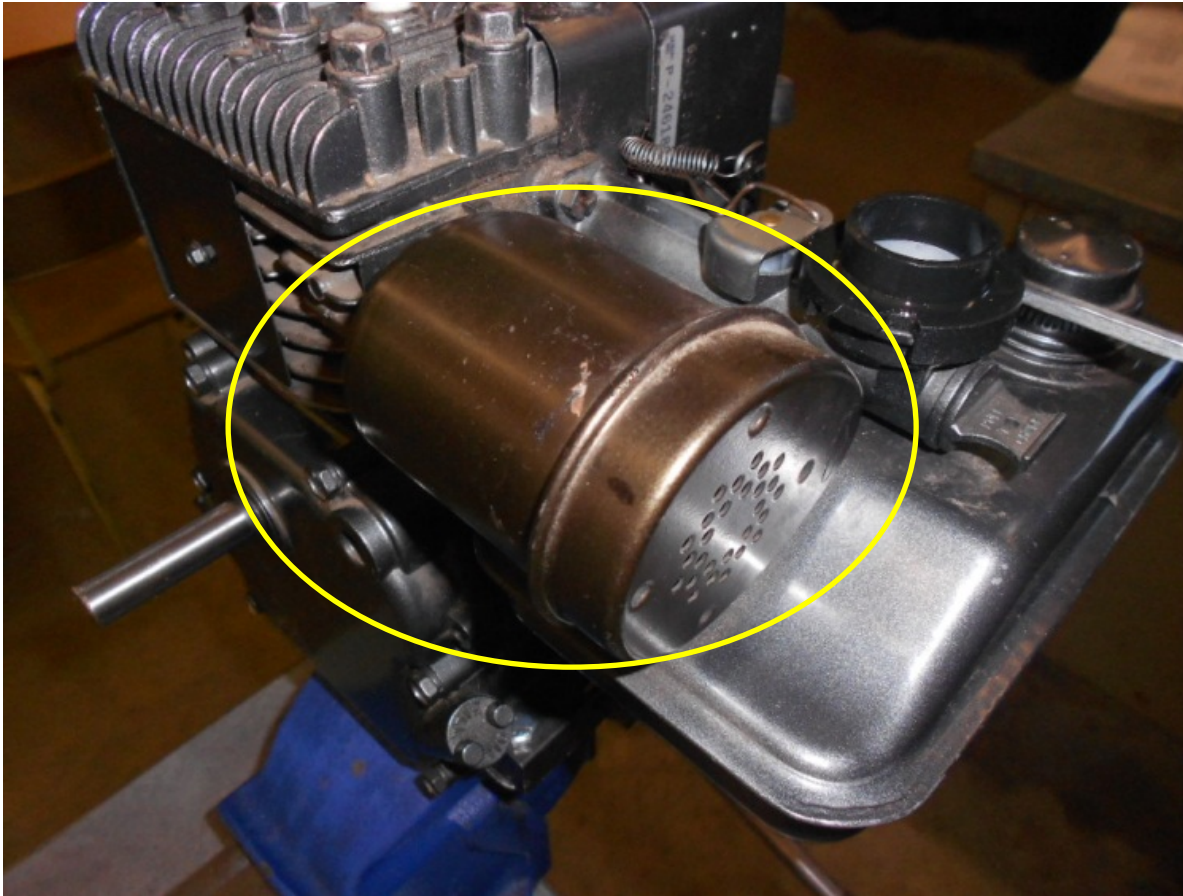

8. Caution: Air intake can 'suck' in hair!

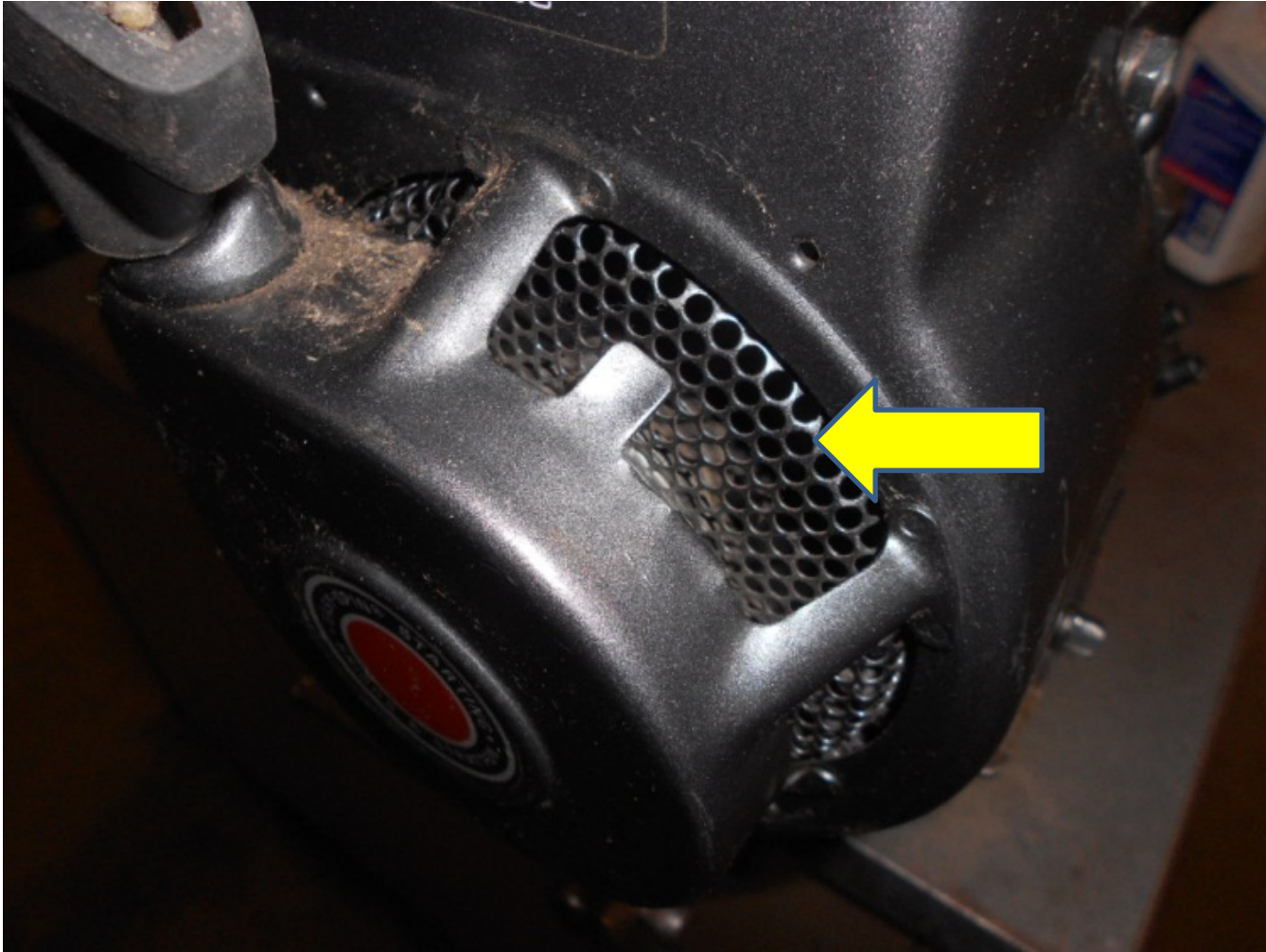

8. Caution: Spinning crankshaft on 'less visible side of engine'.

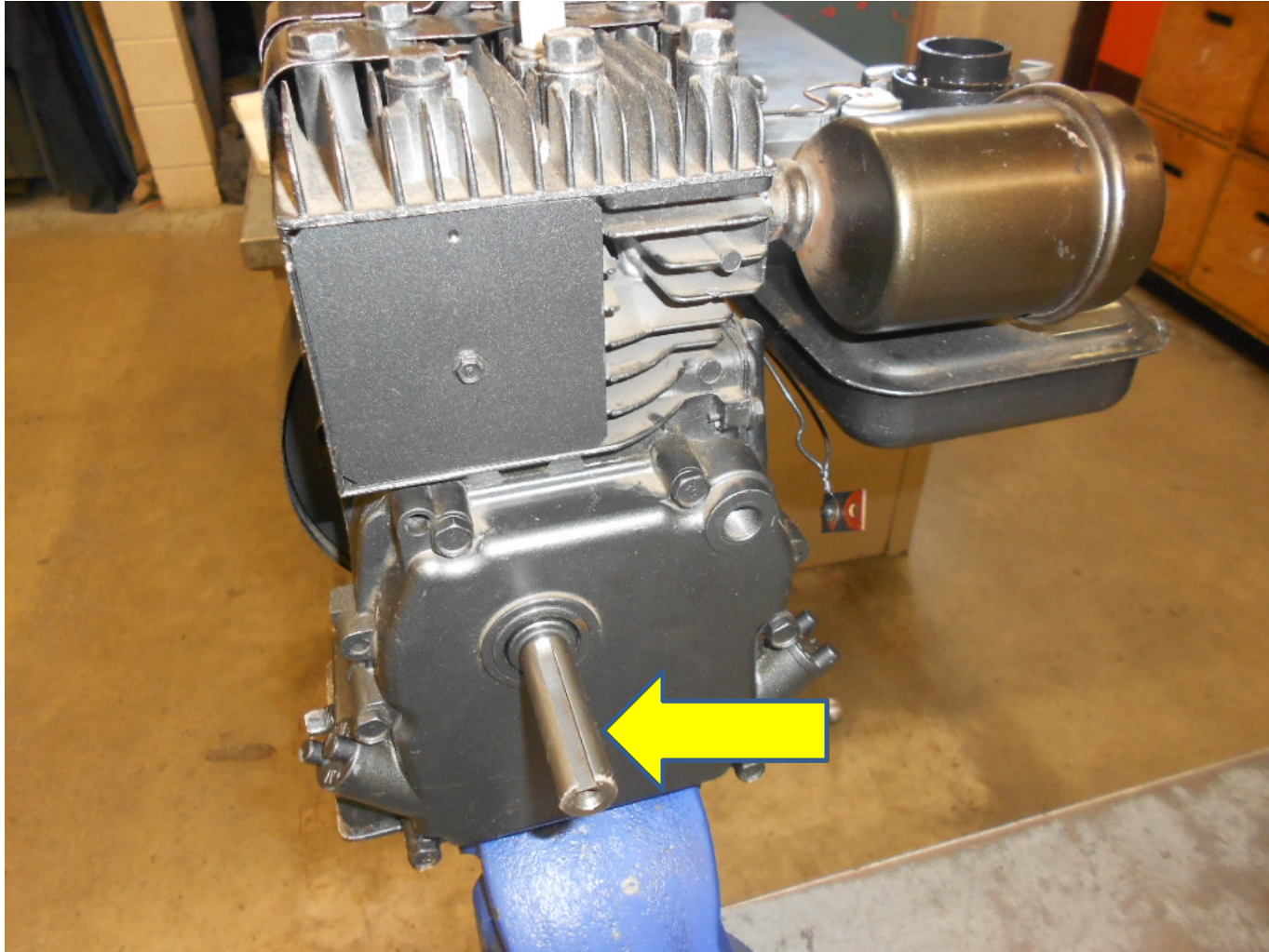

9. Once engine is sufficiently warm Make final adjustments to carburetor. FIRST the mixture, THEN idle speed.

1. Start and run engine at half throttle for five minutes to bring engine up to operating temperature.
2. Place governor speed control lever in "FAST" position.
3. Turn needle valve in until engine misses (clockwise – lean mixture) then turn it out past

smooth operation point
(counterclockwise – rich mixture).

4. Turn needle valve to midpoint between rich and lean so engine runs smoothly.

Final Adjustment, except Low Emissions Carburetors

3

1. Place equipment control lever in "SLOW" position.
2. Turn needle valve in until engine slows (clock-wise – lean mixture).
3. Turn needle valve out past smooth operating point until engine runs unevenly (rich mixture).
4. Turn needle valve to midpoint between rich and lean so engine runs smoothly.
5. Adjust idle RPM. Rotate throttle shaft counterclockwise and hold against idle stop while adjusting idle speed adjusting screw to obtain 1750 RPM.

6. Hold throttle shaft in the idle position. Move speed control to fast position.
7. Release throttle shaft. Engine should accelerate without hesitation or sputtering.
8. If engine does not accelerate smoothly, carburetor should be readjusted, usually to a slightly richer mixture.

9. Adjusting Speed:

1. Set Tachometer to 1750 RPM.
2. Rotate throttle valve fully counterclockwise and hold.
3. Hold tachometer on top of engine while engine is running at full throttle.
4. Adjust idle set screw until wire extending from tach pulses widely (in synch with engine pulsations)

