

# Valves

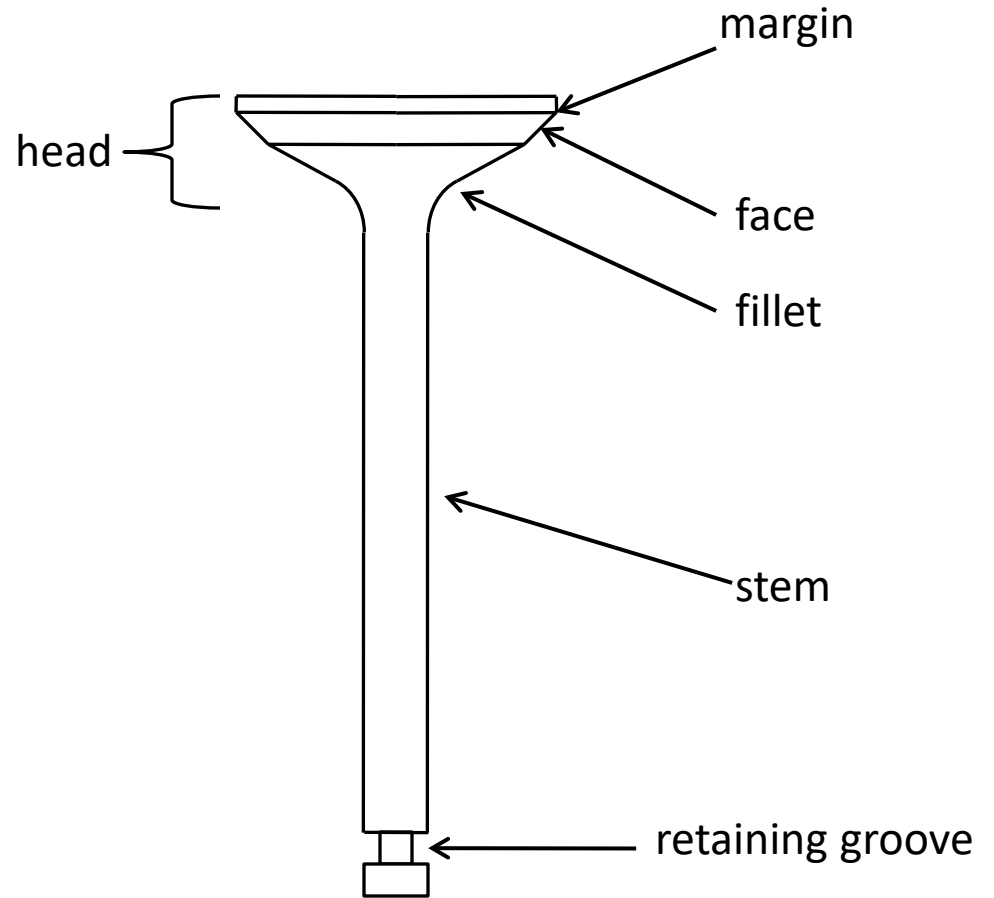

## Parts of a Valve



Draw a Valve

## Purpose of a Valve

*To control the flow of gases in and out of the cylinder*

## Goals for a valve

- *Seal gas tight when closed*
- *Be of minimum obstruction when open*



## Checking for 'Spec.'

You are about to remove and reinstall the valves in you engine.

Prior to installing you will be asked to inspect the valve margins and seats to determine if they meet 'spec.'

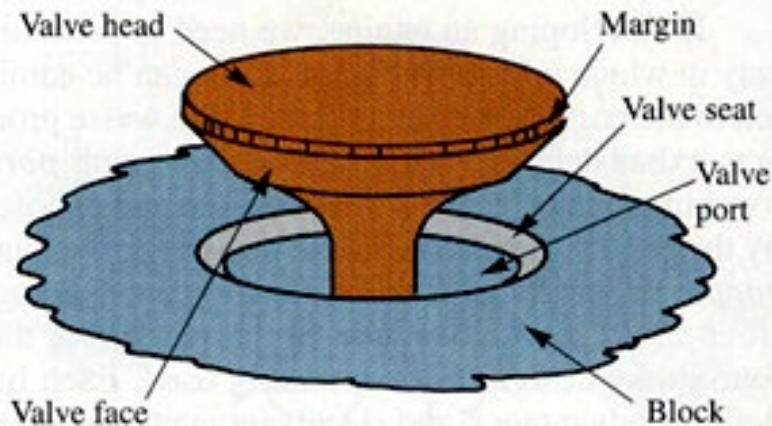

**Figure 4-24.** Valve face and valve seat must be ground to correct angles, and concentric to centerline of guide, to seal properly.

## Checking for 'Spec.'

### Inspecting valve margins...

The margin is unacceptable if it is too thin.

Reason:

If it is too small it won't be able to handle the heat in the combustion chamber.

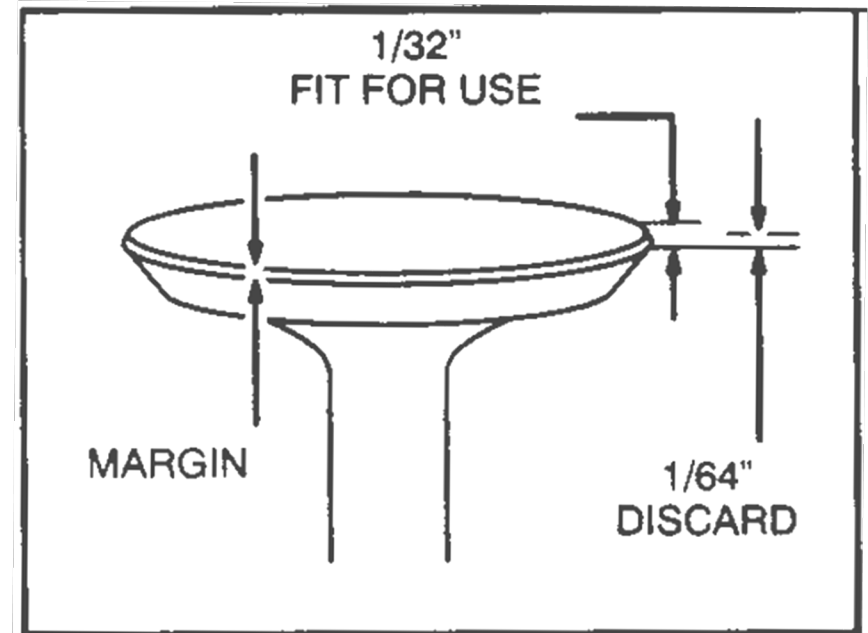

Fig. 6 - Valve and Seat Dimensions

## Checking for 'Spec.'

### Inspecting the valve's seat

The seat is not allowed to be too narrow or too wide.

Too narrow:

- Poor heat transfer, can lead to burnt valve.
- Physical damage to seat.

Too wide:

- Carbon gets stuck between face and seat holding valve open; leads to burnt valve

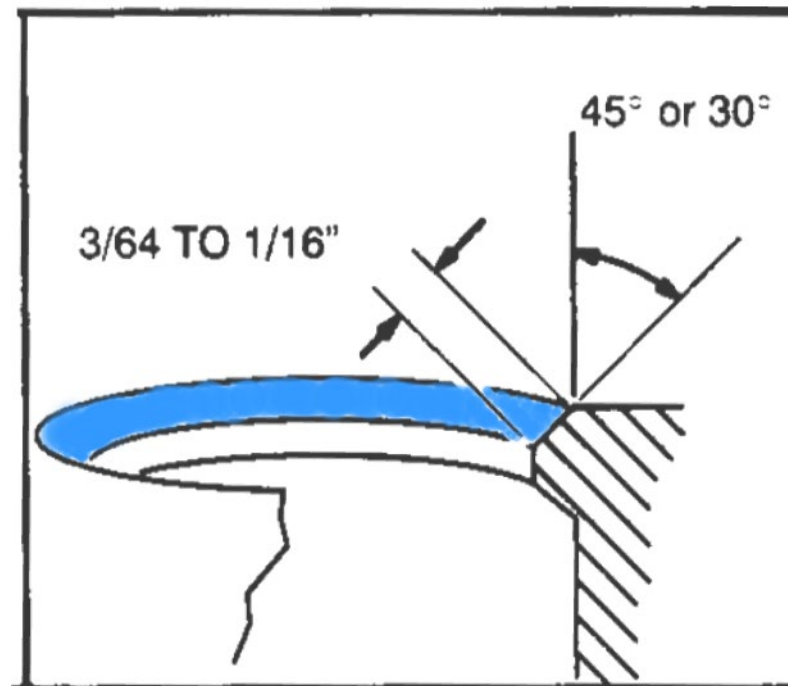

## The 'Valve Train'

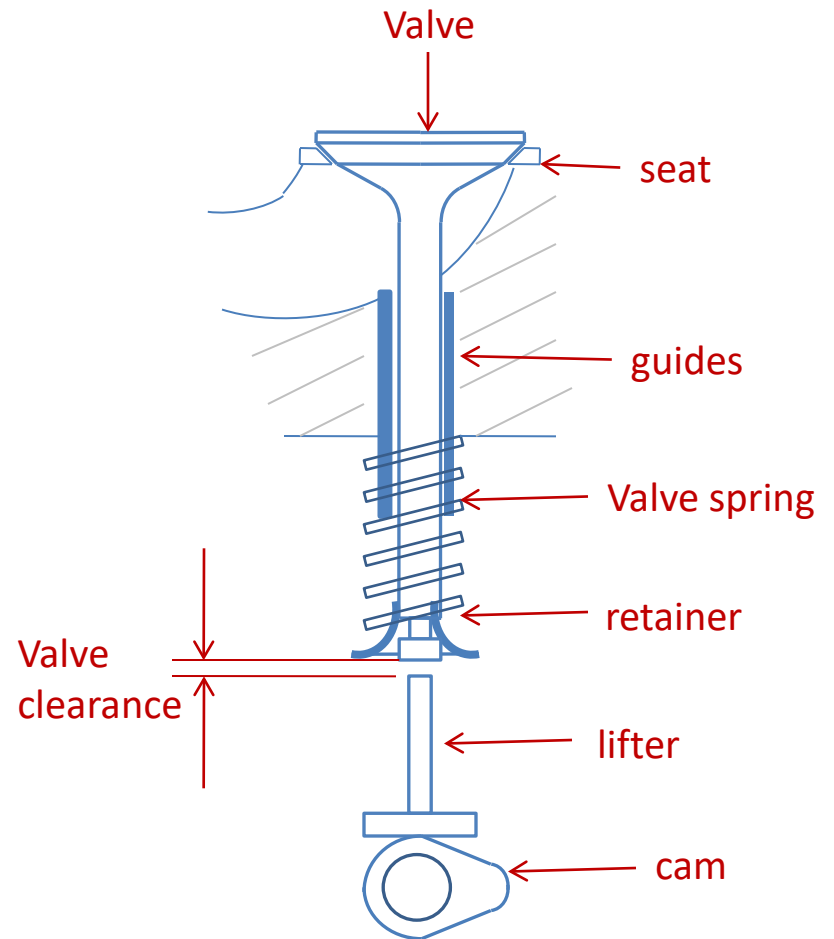
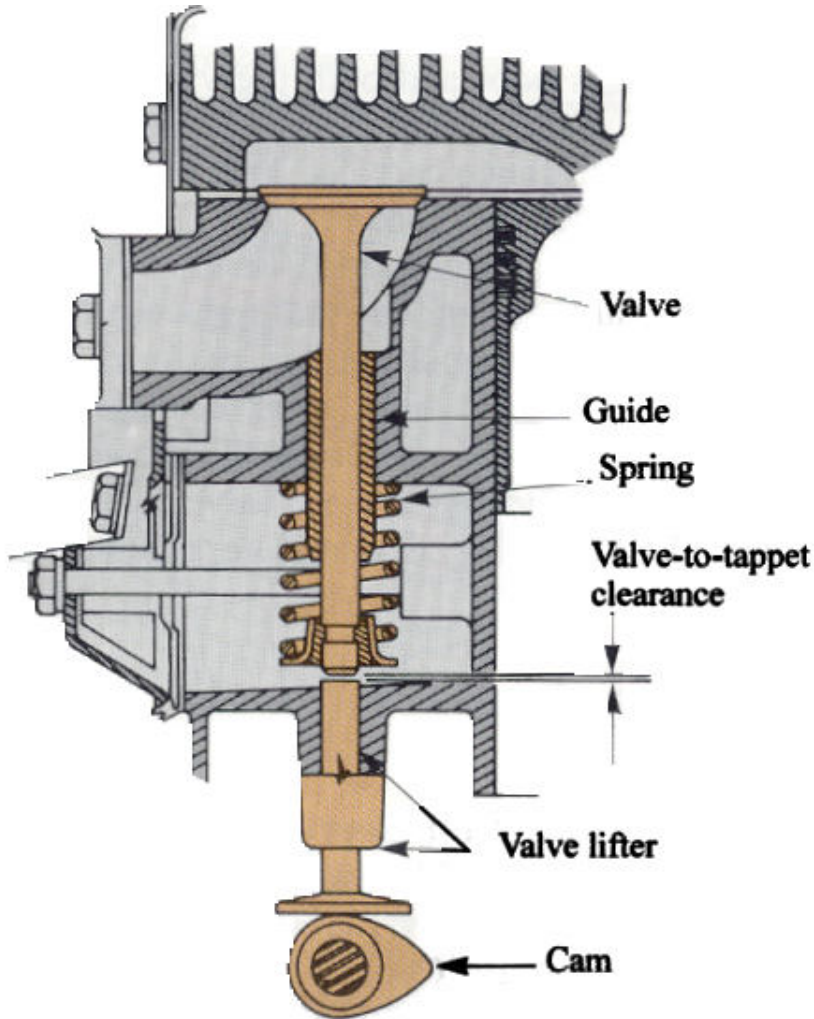

**Figure 17-61.** *Components of a complete valve train.*  
(Kohler Co.)

Notes: Draw the Valve Train

## Understanding Valve Gap / Clearance

Valve (or tappet) clearance is necessary to ensure that the valve closes completely when it should.

Valve clearance is measured in thousandths of an inch, or hundredths of a millimeter!

To understand why it has to be so exact consider the following...

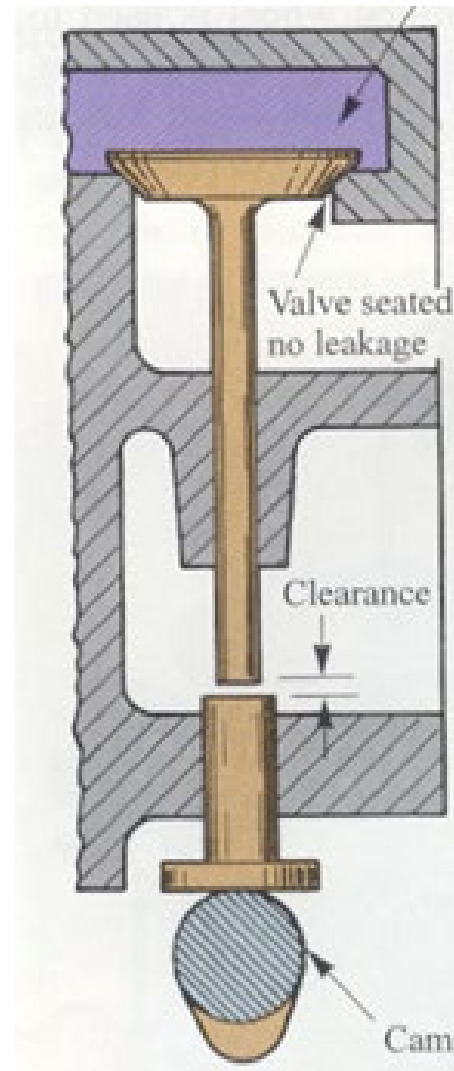



## Understanding Valve Gap / Clearance cont'd.

### Extreme Scenario #1 – Gap too small (nonexistent)

Why is it not acceptable to have zero valve clearance when the engine is cold, even if we could be sure that the valve was seated?

### Answer

When the engine is started and warms up the metal parts of the valve train will expand and this will result in the valve being held off of its seat.

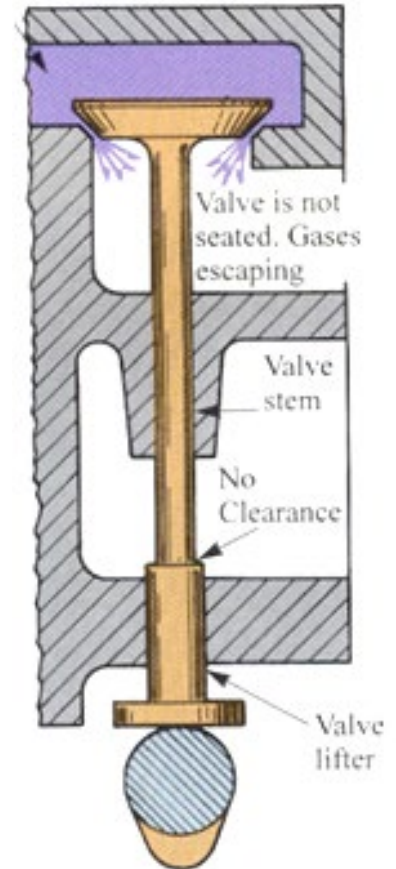

## Understanding Valve Gap / Clearance cont'd.

### Extreme Scenario #2 – Gap far too big

Why would it not be desirable to have an extremely big valve gap?

### Answer

1. Much of the cam lobe's raising effort would be lost in closing the large gap.
2. The valve's 'lift' would be less and this would reduce the flow of gases.

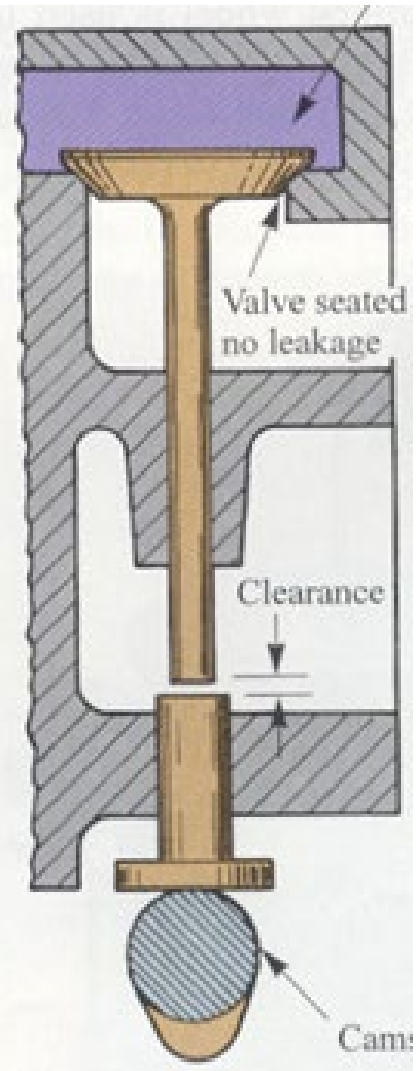

## Understanding Valve Gap / Clearance cont'd.

Therefore the valve gap cannot be too big or too small, it must be just right!

### Section 6 Page 13

**VALVE TAPPET CLEARANCE**

BASIC MODEL SERIES	INTAKE		EXHAUST	
	MIN.	MAX.	MIN.	MAX.
60000, 80000, 90000*, 100000, 110000, 120000	.005	.007	.007*	.009*
130000, 170000, 190000, 220000, 250000●, 280000***	.005	.007	.009	.011
<b>CAST IRON CYLINDER</b>				
230000, 240000, 300000, 320000	.007	.009	.017	.019

The size is specified by the manufacturer and is found in the service manual.

## Understanding Valve Gap / Clearance cont'd.

To measure valve gap a tool called a 'feeler gauge' or 'thickness gauge' is used.



Now let's put it all together, literally!



Vintage VW Automotive Training Video – Valves  
(5 min.)

# Valves

---

